

Fluxgate Closed Loop Current Sensor CYFGCS3000AIT-40mA

CYFGCS3000AIT-40mA is a current sensor based on the fluxgate closed-loop principle, and can be used for measuring DC, AC, pulse and various irregular waveform currents under galvanic isolation conditions.

The multi-point zero-flux technology is applied to existing high-precision DC sensor technology. By combining excitation flux closed-loop control, self-excitation flux gate technology, and multi-loop control, it achieves zero-flux closed-loop control of excitation flux, DC flux, and AC flux. Additionally, by establishing a high-frequency ripple sensing channel, it enables the detection of high-frequency ripple, thereby providing the sensor with high gain and measuring accuracy across the entire bandwidth.

Core Technologies

- Closed-loop excitation flux control technology
- Self-excitation demagnetization technology
- Multi-point zero-flux technology
- Multi-range automatic switching technology
- Temperature compensation technology

Performance Features

- Primary-to-secondary isolation measurement
- Excellent linearity and accuracy
- Extremely low temperature drift
- Extremely low zero drift
- Strong resistance to electromagnetic interference
- Wide bandwidth and fast response time

Technical Data

Parameters	Symbol	Test Conditions	Values	Unit
Supply Voltage	V_{AC}		220	V
Rated input current DC	I_{PN_DC}		± 3000	A
Rated input current AC RMS	I_{PN_AC}		2121	A
Current measuring range	I_{PM}		$0 \sim 1.1 \times I_{PN}$	A
Overload Current DC	I_{PM_DC}	1 min	± 3600	A
Current output mode 1				
Current to current ratio	K_{N1}	Input : Output	3000 : 1000	A/mA
Rated output current DC	I_{OUT}	Rated input current	± 1000	mA
Measuring resistance	R_M		$0 \sim 0.5 \sim 1.5$	Ω
Current consumption	I_C	Rated input current	$\pm(40 \sim 130) + I_{OUT}$	mA
Current output mode 2				
Current to current ratio	K_{N2}	Input : Output	3000:40	A/mA
Rated output current DC	I_{OUT}	Rated input current	± 40	mA
Output resistance	R_M		10	m Ω
Current consumption	I_C	Rated input current	$\pm 40 \sim \pm 440 \sim \pm 530$	mA

Measuring Accuracy

Parameters	Symbol	Test Conditions	Values	Unit
Linearity	ϵ_L	Whole measuring range	$\leq \pm 20$	ppm
Accuracy ($T_A = -25^\circ\text{C} \pm 20^\circ\text{C}$)	X	DC input current	$\leq \pm 50$	ppm
Temperature stability	T_C		$\leq \pm 0.5$	ppm/ $^\circ\text{C}$
Time stability	T_T		$\leq \pm 0.5$	ppm/month
Power Supply Immunity	T_V		$\leq \pm 1$	ppm/V
Zero point offset current	I_O	$T_A = 25^\circ\text{C}$	$\leq \pm 1$	ppm
Zero point offset current	I_{OT}	$T_A = -40^\circ\text{C} \sim 85^\circ\text{C}$	$\leq \pm 5$	μA
Following accuracy	di/dt	Current output mode 1	≥ 100	A/ μs
	di/dt	Current output mode 2	≥ 14	A/ μs
Response time	T_r	$di/dt = 100\text{A}/\mu\text{s}$, 90% I_{PN}	≤ 1 (mode 1)	μs
		$di/dt = 14\text{A}/\mu\text{s}$, 90% I_{PN}	≤ 7 (mode 2)	μs
Bandwidth (-3dB)	F		DC~100	kHz

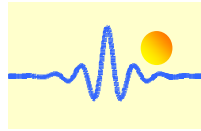

Safety Features

Parameters	Symbol	Test Conditions	Values	Unit
Isolation voltage	V_d	50Hz, 1min	5	kV
Transient isolation voltage	V_w	50 μ s	10	kV
Creepage distance	dCp	Primary side to enclosure	21	mm
Electrical Clearance	dCi	Primary side to enclosure	25	mm
Comparative tracking index	CTI	IEC-60112	600	V

General Features

Parameters	Symbol	Test Conditions	Values	Unit
Operating temperature	T_A		-40~+85	$^{\circ}$ C
Storage temperature	T_s		-55~+95	$^{\circ}$ C
Relative humidity	RH		20-80	%
Mass	m		9.5 \pm 0.5	kg

Operating Status Description

◇ During normal operation, the green light remains on:

After the device is powered on, the green indicator light remains on when the device is functioning normally. If the green light does not illuminate after connecting the power supply, you should first check whether the sensor's power supply is functioning properly.

◇ During a current overload, the green indicator light is off:

If the green indicator is off while the power supply is functioning normally, this indicates that the current sensor is in a non-zero flux state. At this point, the bus input current amplitude exceeds the specified range, causing the sensor to enter a scanning state, and the output current is no longer proportional to the input current signal. Once the input current returns to within the specified measuring range, the sensor's output current also returns to normal, and the green indicator remains lit.

Instructions for Use

Follow these steps:

Step 1: Connect the sensor to the control box using the dedicated connection cable.

Step 2: Plug the 220V AC power cord into the control box and turn on the power switch.

Step 3: Feed the cable carrying the current to be measured through the sensor's opening, paying attention to the direction of the current.

Step 4: For current output, connect the red and black banana plug connectors to a current measuring instrument or current sampling circuit. Note that the sampling resistance must not exceed the maximum limit.

Step 5: For voltage output, connect the BNC connector to a voltage measuring instrument or oscilloscope. Note that the current output terminal must be short-circuited at this time.

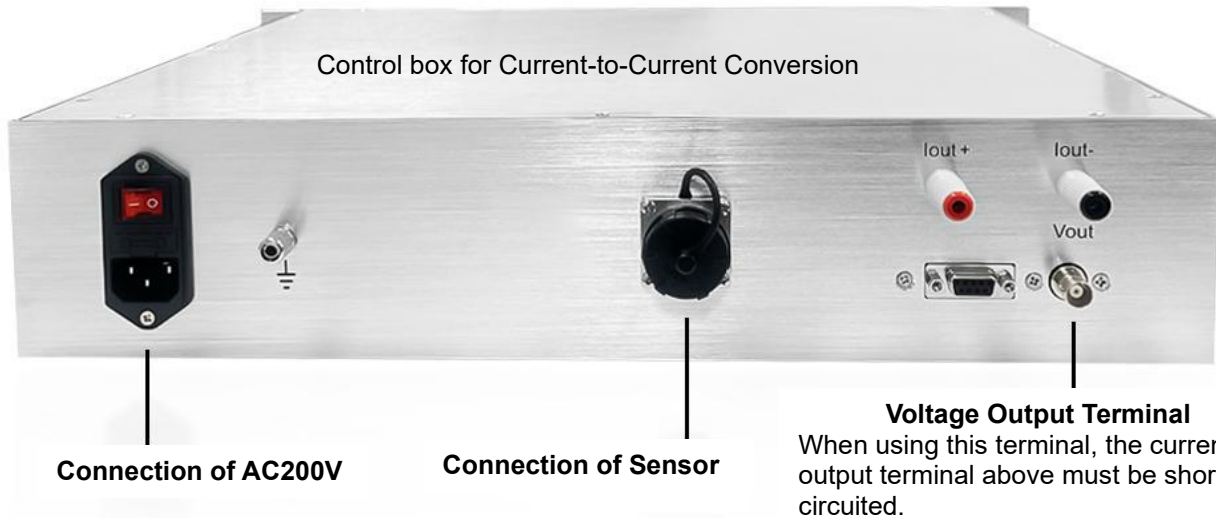
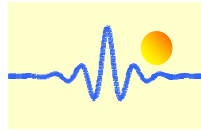

Port Configuration

Port Configuration Overview

Item	Port type	Unit	Quantity	Description
1	BNC	piece	1	Voltage output 10V
2	GX16 Aviation Connector	piece	1	6 Pole female connector, connect to current sensor
3	Banana Plugs	set	1	Each set includes a positive (red) and a negative (black) output, for outputting a single current signal
4	Toggle Switch	piece	1	Power On/Off Switch
5	Power Outlet	piece	1	Three-prong outlet, for connecting the power supply
6	Grounding post	piece	1	Chassis grounding terminal

6-Pin GX16 Aviation Connector Pinout Chart

Pin	Definition	Description
1	+15V	DC Power supply +Vcc
2	-15V	DC Power supply -Vcc
3	GND	Ground of power supply and signal output
4	Output	Sensor secondary output current +
5	NC	Not connected
6	NC	Not connected

Application Connections and Instructions

◇ Control Box Power Supply Wiring:

Connect the control box power supply interface directly to a 220V power source;
Red terminal: Positive terminal for secondary current output;
Black terminal: Negative terminal for secondary current output;
BNC connector: Voltage output terminal;

◇ Connection between the control box and the probe coil:

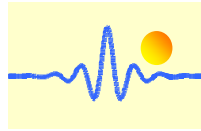

Insert the 6-pin aviation connector at one end of the dedicated connection cable into the sensor's 6-pin aviation socket and tighten to secure; insert the aviation connector at the other end of the dedicated connection cable into the control box's aviation socket and tighten to secure.

Precautions for Use

- ◇ The load on the voltage output port must be greater than 3 k Ω , and the load current must be less than 5 mA.
- ◇ Do not short-circuit the positive and negative terminals of the voltage output port.
- ◇ When outputting voltage, the red and black terminals for current output must be short-circuited; you can select either current signal output or voltage signal output mode as needed.

Case Style and Connection

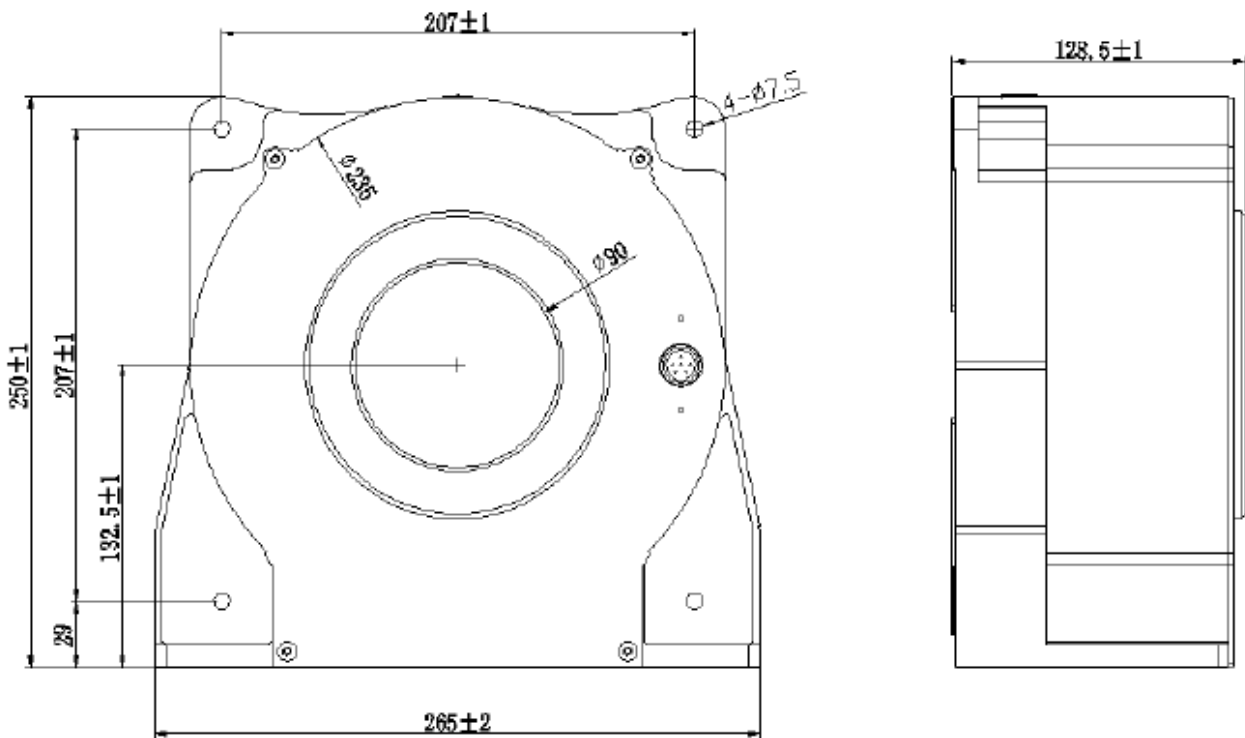

Unit: mm

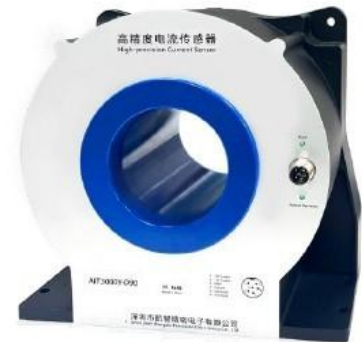

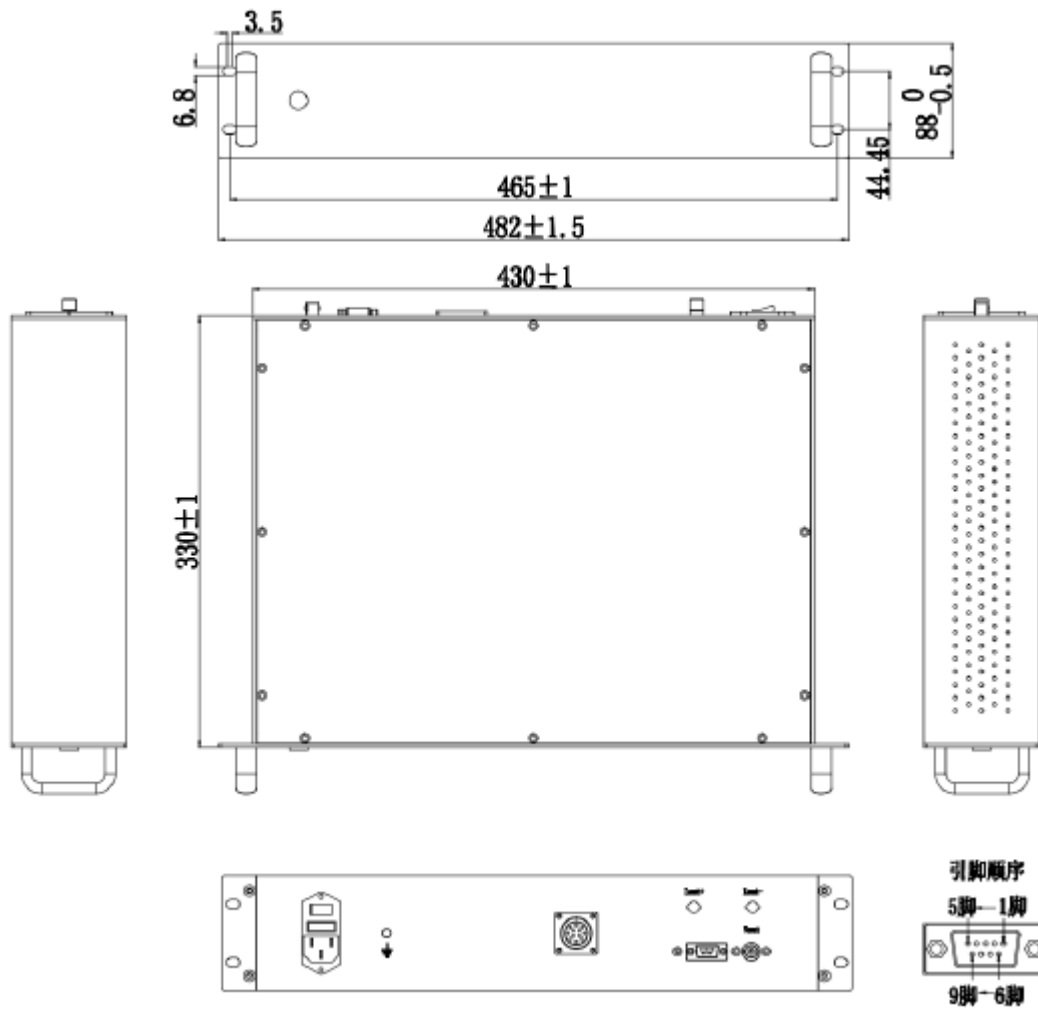
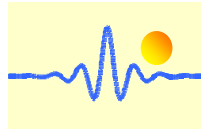

Control box for Current-to-Current Conversion

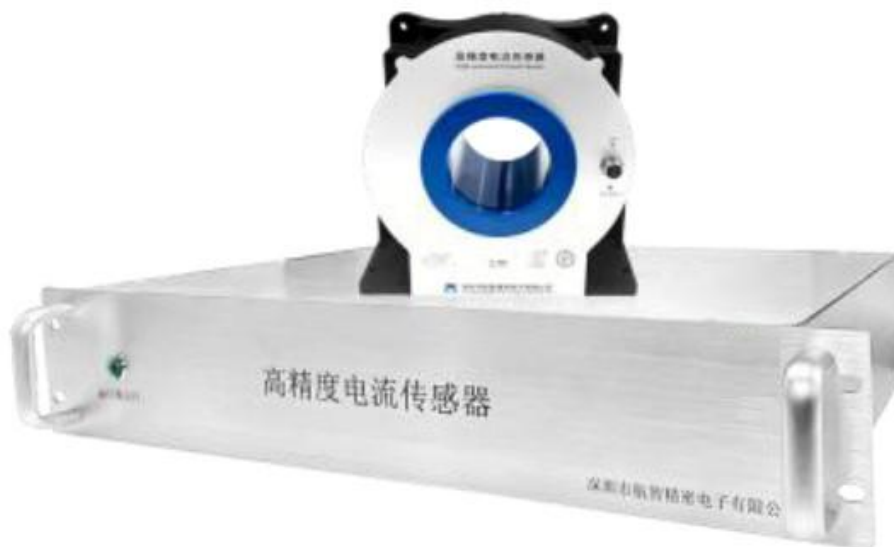

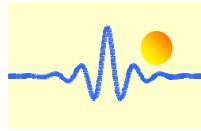

Application Areas

- Medical Equipment: Scanners, MRI
- Power: Converters, Inverters
- New Energy: Photovoltaics, Wind Power
- Automotive: Electric Vehicles
- Naval: Electric-powered Ships
- Aerospace: Satellites, Rockets
- Metrology: Verification and Calibration
- Rail Transit: High-speed Trains, Subways, Trams and Trolleys
- Test and measuring instruments: Power analyzers, high-precision power supplies
- Smart grid measurement: Power generation, battery monitoring, medium- and low-voltage substations
- Industrial control: Industrial motor drives, welding, robotics, cranes, elevators, ski lifts