

DC Current Sensor with Split Core CYHCT-L65K

The sensor CYHCT-L65K is based on open loop principle and designed with a high galvanic isolation between primary conductor and secondary circuit. It can be used for measurement of DC current, DC pulse currents etc. The output of the transducer reflects the real wave of the current carrying conductor.

Features and Advantages	Applications
<ul style="list-style-type: none"> • DC current measurement • Output signal option (4-20mA, 0-5V, 0-10V....) • High isolation between primary and secondary circuits • Split Core, easy installation • Protection against overvoltage • Protection against reversed polarity • Output protection against electrical disturbances 	<ul style="list-style-type: none"> • Photovoltaic equipment • Battery banks, such as, monitoring load current and charge current, verifying operation • Transportation, measuring traction power or auxiliary loads • Phase fired controlled heaters • Directly connect to PLC • Sense motor stalls and short circuits • Industrial instrumentation

Electrical Data

Measuring range M	300A ~ 6000A DC
Linear measuring range	1.2 x M (for 300A ~ 5000A), 6500A (for >5000A)
Overload capacity	5 x M _{max} (maximum measuring range)
Nominal output signals	0-4V, 0-5V, 0-10V, -5V~+5V, 0-20mA, 4-20mA, -20mA~+20mA
Supply voltage	+12VDC, +15VDC, +24VDC, ±12VDC, ±15VDC
Current consumption	18mA ~ 50mA + output current
Galvanic isolation	6KV RMS/50Hz/min, Isolation resistance ≥100MΩ

Accuracy and Dynamic Performances

Zero offset voltage/Current	±20mV for 0-5V output, ±0.2mA for current output
Hysteresis error	±10mV for 0-5V output, ±0.1mA for current output
Thermal drift of offset	≤500ppm/°C
Thermal Drift (-10°C to 50°C)	<1000ppm /°C
Response time	≤1ms (di/dt=50A/μs)
Accuracy	±1.0%FS for 300A~999A, ±0.5%FS for 1000A~6000A
Linearity	±0.5%FS for 300A~999A, ±0.2%FS for 1000A~6000A
Frequency Bandwidth (-3dB)	DC – 8kHz

General Data

Operating temperature	-40°C ~ +85°C
Storage temperature	-40°C ~ +100°C
Protection of Case	IP20
MTBF	≥ 100k hours
Unit Weight	940g ~ 980g

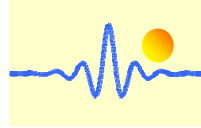

Definition of Part number:

CYHCT	-	L65K	-	M	-	x	n
(1)		(2)		(3)		(4)	(5)

(1)	(2)	(3)	(4)	(5)
Series name	Case style	Rated Input current (M=U/B + m)	Output signal	Power supply
CYHCT	L65K	m = 300A, 400A, 500A, 600A, 700A, 800A, 1000A, 2000A,3000A, 4000A, 5000A,6000A	x=0: 0-4V DC x=3: 0-5V DC x=4: 0-20mA DC x=5: 4-20mA DC x=8: 0-10V DC	n=2: +12V DC n=3: +15V DC n=4: +24V DC n=5: ±12V DC n=6: ±15V DC

U: unidirectional input current; **B:** bidirectional input current

Output Signal of Custom Made Sensors:

x=1: tracing voltage ±5V DC, **x=2:** tracing current ±20mA DC

Example 1: CYHCT-L65K-U1000A-34, Hall Effect DC Current sensor with
Output signal: 0-5V DC
Power supply: +24V DC
Rated input current: 0-1000A DC

Example 2: CYHCT-L65K-B1000A-34, Hall Effect
DC Current sensor with
Output signal: 0-5V DC
Power supply: +24V DC
Rated input current: -1000A ~ +1000ADC



DIMENSIONS (mm)

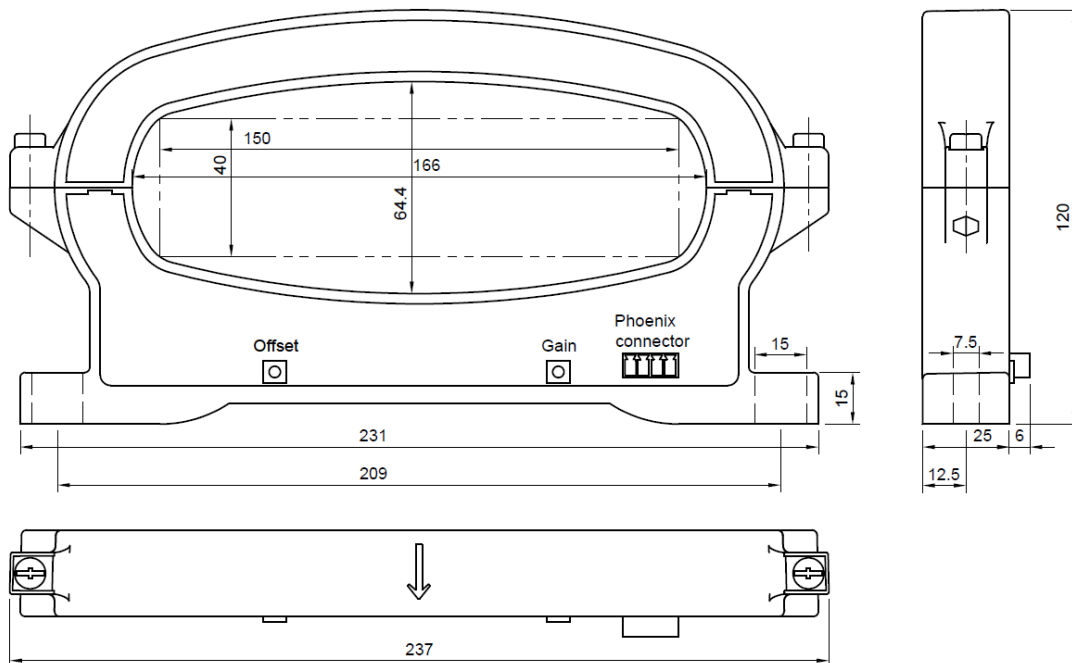

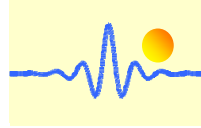

CONNECTION

The current carrying cable must pass through the window. The phase of output is the same as that of the current passing the window in the direction of the arrow indicated on the case.

a) Wiring of Sensors Using Double Power Supplies

Voltage Output

- 1(+): +15V/+12V Power Supply
- 2(-): -15V/-12V Power Supply
- 3(M): Output
- 4(G): Ground

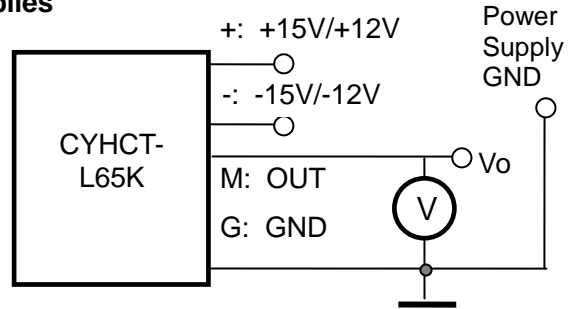

Relation between Input and Output:

Sensor CYHCT-L65K-U1000A -35		Sensor CYHCT-L65K-B1000A -35	
Input current (A)	Output voltage (V)	Input current (A)	Output voltage (V)
0	0	-1000	0
250	1.25	-500	1.25
500	2.5	0	2.5
750	3.75	500	3.75
1000	5	1000	5

Current Output

- 1(+): +15V/+12V Power Supply
- 2(-): -15V/-12V Power Supply
- 3(M): Output
- 4(G): Ground

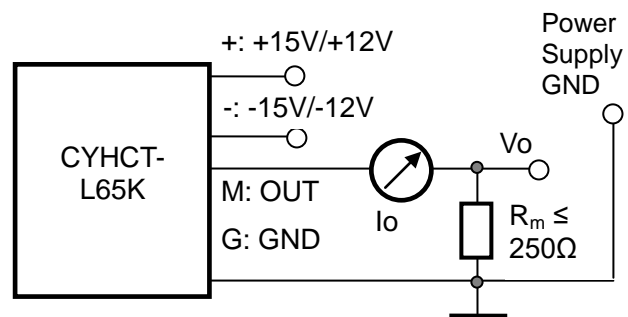

Relation between Input and Output (for $R_m=250\ \Omega$):

Sensor CYHCT-L65K-U1000A -45			Sensor CYHCT-L65K-B1000A -45		
Input current (A)	Output current I_o (mA)	Output voltage V_o (V)	Input current (A)	Output current I_o (mA)	Output voltage V_o (V)
0	0	0	-1000	0	0
250	5	1.25	-500	5	1.25
500	10	2.5	0	10	2.5
750	15	3.75	500	15	3.75
1000	20	5	1000	20	5

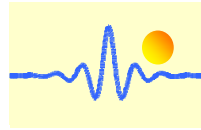

B) Wiring of Sensors Using Single Power Supply

Voltage Output

1(+): +15V, +12V, +24V
2(-): NC
3(M): Output
4(G): Ground

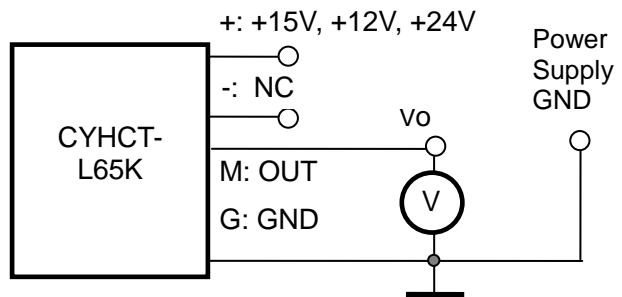

Relation between Input and Output:

Sensor CYHCT-L65K-U1000A -34		Sensor CYHCT-L65K-B1000A -34	
Input current (A)	Output voltage (V)	Input current (A)	Output voltage (V)
0	0	-1000	0
250	1.25	-500	1.25
500	2.5	0	2.5
750	3.75	500	3.75
1000	5	1000	5

Current Output

1(+): +15V, +12V, +24V
2(-): NC
3(M): Output
4(G): Ground

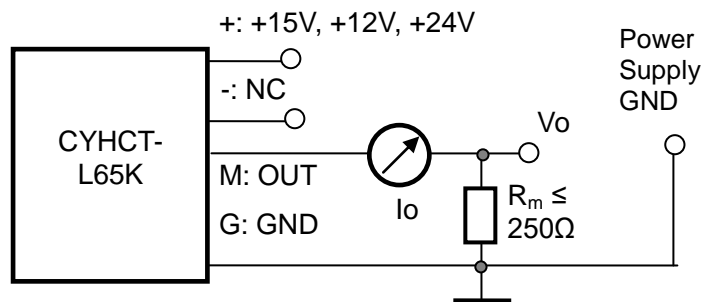

Relation between Input and Output (for $R_m=250 \Omega$):

Sensor CYHCT-L65K-U1000A -54			Sensor CYHCT-L65K-B1000A -54		
Input current (A)	Output current I_o (mA)	Output voltage V_o (V)	Input current (A)	Output current I_o (mA)	Output voltage V_o (V)
0	4	1	-1000	4	1
250	8	2	-500	8	2
500	12	3	0	12	3
750	16	4	500	16	4
1000	20	5	1000	20	5

Notes:

1. Connect the terminals of power source, output respectively and correctly, never make wrong connection.
2. Two potentiometers can be adjusted, only if necessary, by turning slowly to the required accuracy with a small screwdriver.
3. The best accuracy can be achieved when the window is fully filled with bus-bar (current carrying conductor).
4. The in-phase output can be obtained when the direction of current of current carrying conductor is the same as the direction of arrow marked on the transducer case.