

## Split Core Hall Effect DC Current Sensor CYHCT-KF2C

This Hall Effect current sensor is based on open loop principle and designed with a high galvanic isolation between primary conductor and secondary circuit. It can be used for measurement of DC current, DC pulse currents etc. The output of the transducer reflects the real wave of the current carrying conductor.

Product Characteristics	Applications
<ul style="list-style-type: none"> <li>• Excellent accuracy</li> <li>• Very good linearity</li> <li>• Using split cores and easy mounting</li> <li>• Less power consumption</li> <li>• Window structure with split core</li> <li>• Electrically isolating the output of the transducer from the current carrying conductor</li> <li>• No insertion loss</li> <li>• Current overload capability</li> </ul>	<ul style="list-style-type: none"> <li>• <b>Photovoltaic equipment</b></li> <li>• Frequency conversion timing equipment</li> <li>• Various power supplies</li> <li>• Uninterruptible power supplies (UPS)</li> <li>• Electric welding machines</li> <li>• Transformer substation</li> <li>• Numerical controlled machine tools</li> <li>• Electric powered locomotive</li> <li>• Microcomputer monitoring</li> <li>• Electric power network monitoring</li> </ul>

### Electrical Data

Primary Nominal DC Current $I_r$ (A)	Measuring Range (A)	DC Output Current (mA)	Window Size (mm)	Part number (see application notes on page 3)
300	0~±300	4-20 ±1.0%	85 x 27	CYHCT-KF2C-U/B300A-n
500	0~±500			CYHCT-KF2C-U/B500A-n
600	0~±600			CYHCT-KF2C-U/B600A-n
800	0~±800			CYHCT-KF2C-U/B800A-n
1000	0~±1000			CYHCT-KF2C-U/B1000A-n
1500	0~±1500			CYHCT-KF2C-U/B1500A-n
2000	0~±2000			CYHCT-KF2C-U/B2000A-n
3000	0~±3000			CYHCT-KF2C-U/B3000A-n

(U: unidirectional input current; B: bidirectional input current, please give U or B in Part number)  
(n=3,  $V_{cc}$ = +12VDC ±5%; n=4,  $V_{cc}$ = +15VDC ±5%; n=5,  $V_{cc}$ = +24VDC±5%)

Supply Voltage	$V_{cc}$ = +12V, +15V, +24VDC ± 5%
Output current:	4-20mADC
Current Consumption	$I_c$ < 40mA + Output current
Galvanic isolation, 50/60Hz, 1min:	5kV rms
Isolation resistance @ 500 VDC	> 500 MΩ

### Accuracy and Dynamic performance data

Accuracy at $I_r$ , $T_A=25^\circ\text{C}$ ,	$X < \pm 1.0\%$ FS
Linearity from 0 to $I_r$ , $T_A=25^\circ\text{C}$ ,	$E_L < \pm 0.5\%$ FS
Electric Offset current, $T_A=25^\circ\text{C}$ ,	4±0.03mA DC or 12±0.1mA DC
Magnetic Offset current,	0.1mA
Thermal Drift of Offset Current,	<±0.005mA/°C
Response Time at 90% of $I_P$	$t_r < 1\text{ms}$
Load resistance:	80-450Ω
Frequency Bandwidth (-3dB),	$f_b = \text{DC} - 20\text{kHz}$
Case Material:	PBT

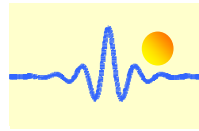

## General Data

Ambient Operating Temperature,  
Ambient Storage Temperature,  
Unit weight,

$T_A = -25^{\circ}\text{C} \sim +85^{\circ}\text{C}$   
 $T_S = -40^{\circ}\text{C} \sim +100^{\circ}\text{C}$   
560g

## Dimensions

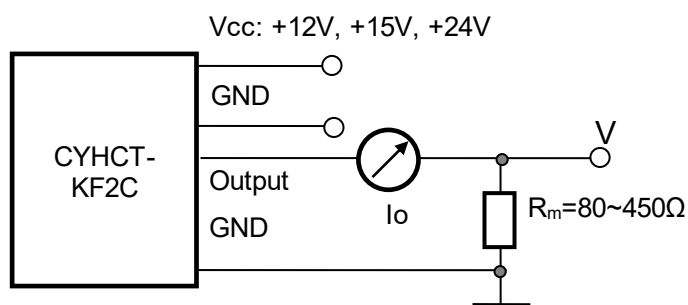
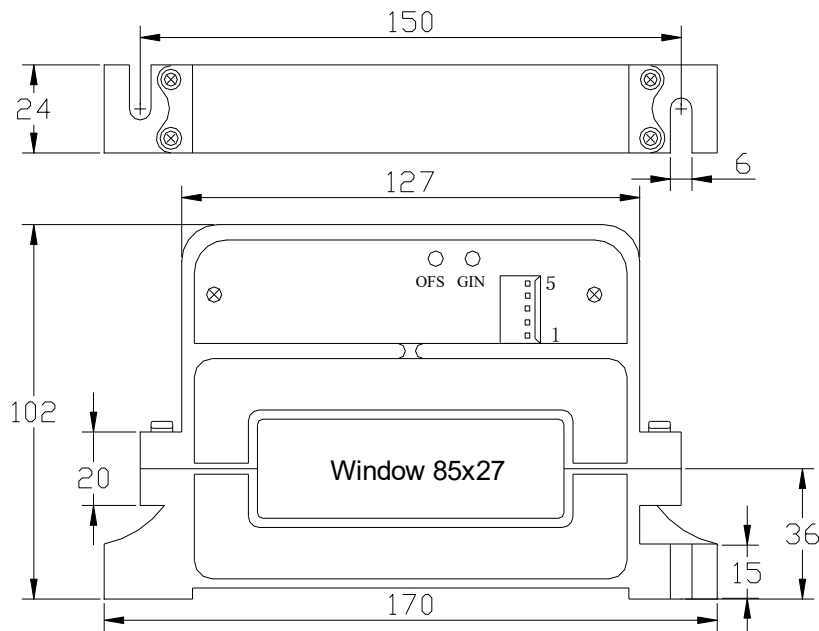

## Pin Arrangement

- 1: Vcc
- 2: Ground (GND)
- 3: Output
- 4: NC
- 5: NC

GIN: gain adjustment  
OFS: offset adjustment

## Notes:

1. Connect the terminals of power source, output respectively and correctly, never make wrong connection.
2. Two potentiometers can be adjusted, only, if necessary, by turning slowly to the required accuracy with a small screwdriver.
3. The best accuracy can be achieved when the primary input cable is positioned at the center of sensor window and occupies over 50% of the window area.
4. The in-phase output can be obtained when the direction of current of current carrying conductor is the same as the direction of arrow marked on the transducer

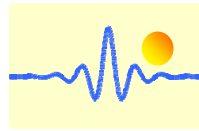

## Application Notes

### 1) Part number CYHCT-KF2C-U/BxxxxA-n

**U:** unidirectional input current; **B:** bidirectional input current; **xxxx:** current value; **n:** power supply (**n=3**,  $V_{cc} = +12VDC \pm 5\%$ ; **n=4**,  $V_{cc} = +15VDC \pm 5\%$ ; **n=5**,  $V_{cc} = +24VDC \pm 5\%$ )

**Example 1:** CYHCT-KF2C-U1000A-5 Hall Effect DC Current sensor with  
Output signal: 4mA - 20mA DC  
Power supply: +24V DC  
Rated input current: 0 - 1000A DC (unidirectional)

**Example 2:** CYHCT-KF2C-B1000A-3 Hall Effect DC Current sensor with  
Output signal: 4mA – 12mA - 20mA DC  
Power supply: +12V DC  
Rated input current: -1000A - 0 - +1000A DC (bidirectional)

### 2) Relation between Input current and output signal

Current Sensor CYHCT-KF2C-U1000A-5		
Input current (A)	Output current $I_o$ (mA)	Output voltage $V_o$ (V) (Measuring resistance $R_m=250\Omega$ )
0	4	1
250	8	2
500	12	3
750	16	4
1000	20	5

Current Sensor CYHCT-KF2C-B1000A-3		
Input current (A)	Output current $I_o$ (mA)	Output voltage $V_o$ (V) (Measuring resistance $R_m=250\Omega$ )
-1000	4	1
-750	6	1.5
-500	8	2
-250	10	1.5
0	12	3
250	14	3.5
500	16	4
750	18	4.5
1000	20	5