

Split Core Hall Effect DC Current Sensor CYHCT-EKOV

This Hall Effect current sensor is based on open loop principle and designed with high galvanic isolation between primary conductor and secondary circuit. It can be used for measurement of DC current etc. The output of the transducer reflects the real wave of the current carrying conductor.

Product Characteristics	Applications
<ul style="list-style-type: none"> • Excellent accuracy • Very good linearity • Less power consumption • Split core window structure • Electrically isolating the output of the transducer from the current carrying conductor • No insertion loss • Current overload capability 	<ul style="list-style-type: none"> • Photovoltaic equipment • Frequency conversion timing equipment • Various power supply • Uninterruptible power supplies (UPS) • Electric welding machines • Electrolyzing and electroplating equipment • Electric powered locomotive • Electric power network monitoring

Technical Data

Primary Nominal DC Current I_r (A)	Primary Current Measuring Range I_p (A)	Output Voltage (V)	Part number (see application notes on page 3)
500A	0 ~ ± 500A	x=0: 0-4V ±1.0%	CYHCT-EKOV-U/B500A-xn
1000A	0 ~ ± 1000A	x=3: 0-5V ±1.0%	CYHCT-EKOV-U/B1000A-xn
2000A	0 ~ ± 2000A	x=8: 0-10V ±1.0%	CYHCT-EKOV-U/B2000A-xn
5000A	0 ~ ± 5000A	(For 0-10V output	CYHCT-EKOV-U/B5000A-xn
8000A	0 ~ ± 8000A	the power supply	CYHCT-EKOV-U/B8000A-xn
10000A	0 ~ ± 10000A	must be 15VDC	CYHCT-EKOV-U/B10000A-xn
12000A	0 ~ ± 12000A	or 24VDC)	CYHCT-EKOV-U/B12000A-xn
15000A	0 ~ ± 15000A	x=S: Special output	CYHCT-EKOV-U/B15000A-xn
20000A	0 ~ ± 20000A		CYHCT-EKOV-U/B20000A-xn

(n=2, V_{cc} = +12VDC; n=3, V_{cc} =+15VDC; n=4, V_{cc} =+24VDC; n=5, V_{cc} =±12VDC; n=6, V_{cc} =±15VDC; n=7, V_{cc} =±24VDC; U: unidirectional, B: bidirectional)

Supply Voltage: V_{cc} =+12V, +15V, +24V, ±12V, ±15VDC ± 5%
Current Consumption (V_{cc} =±15VDC): I_c < 50mA
Isolation Voltage: 6kV, 50/60Hz, 1min

Load Resistor: R_L > 10kΩ
Accuracy at I_r , T_A =25°C (without offset), X < 1.0%
Linearity from 0 to I_r , T_A =25°C, E_L < 1.0% FS
Linear Measuring range, 1.2 times of measuring range
Overload capability, 3 times of measuring range
Electric Offset Voltage, T_A =25°C, V_{oe} < ±25mV
Magnetic Offset Voltage (I_r → 0) V_{om} < ±25mV
Thermal Drift of Offset Voltage, V_{ot} < ±1.0mV/°C
Response Time at 90% of I_p ($f=1$ kHz) t_r < 1ms
Frequency Bandwidth (-3dB), f_b = DC-3kHz
Ambient Operating Temperature: T_A = -25°C ~ +85°C
Ambient Storage Temperature: T_S = -40°C ~ +100°C
Unit Weight: 1165g/pc
Standard: Q/320115QHKJ01-2016

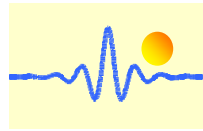

PIN Definition and Dimensions

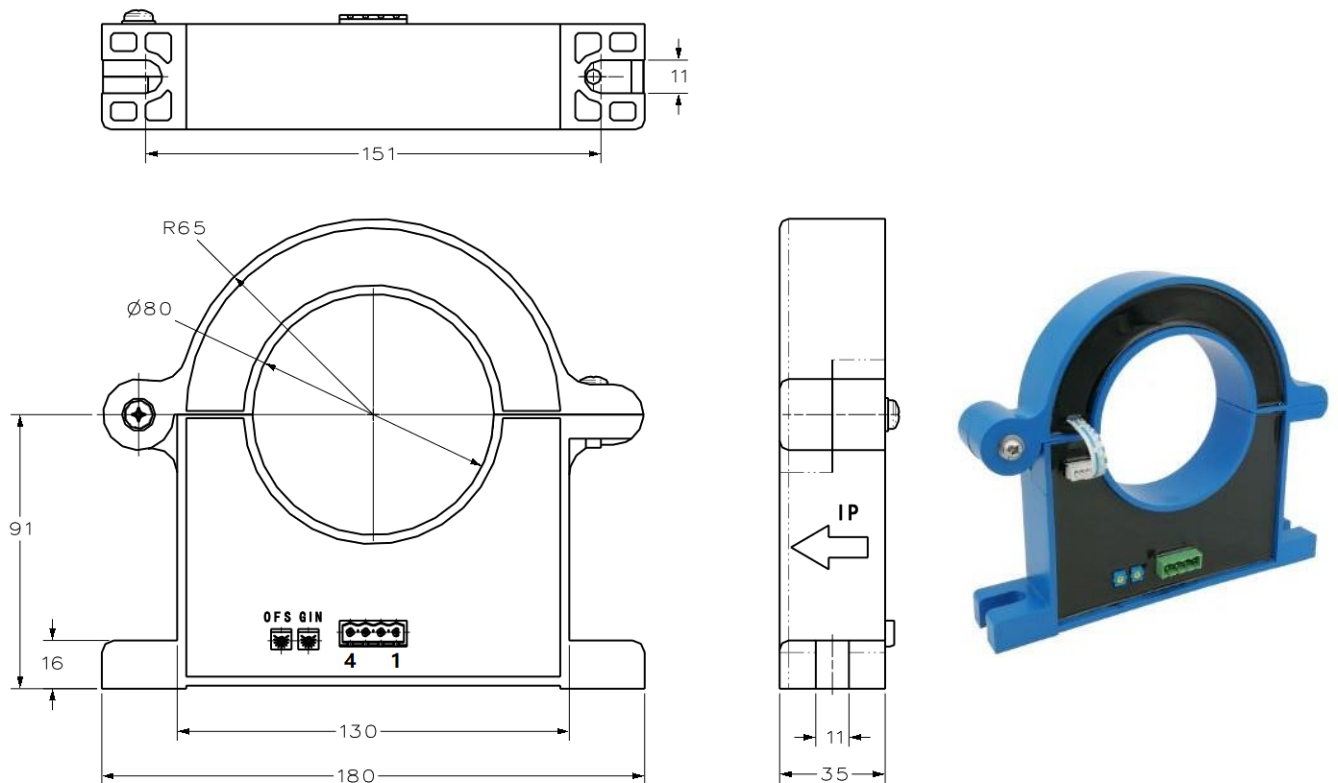

OFS: Offset Adjustment

GIN: Gain Adjustment

Pin arrangement of connector:

1: Vcc 2: -Vcc or GND
3: OUTPUT 4: 0V (GND)

Cable connection:

Red: Vcc
Blue: -Vcc or GND
Yellow: OUTPUT
Black: 0V (GND)

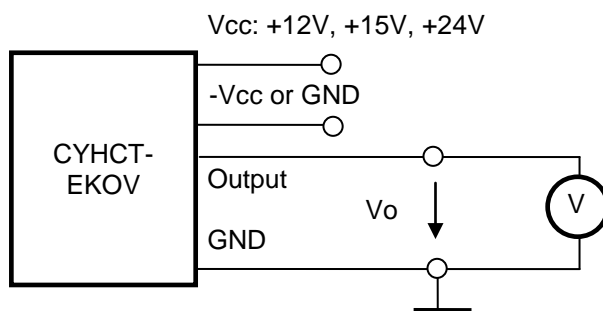

Notes:

1. Connect the terminals of power source, output respectively and correctly, never make wrong connection.
2. Two potentiometers can be adjusted, only if necessary, but slowly to the required accuracy with a small screwdriver.
3. The best accuracy can be achieved when the window is fully filled with current carrying conductor.
4. The in-phase output can be obtained when the current direction of current carrying conductor is the same as the direction of arrow marked on the transducer

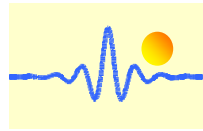

Application Notes

1) Part number CYHCT-EKOV-U/BxxxxA-xn

U: unidirectional input current; **B:** bidirectional input current; **xxxx:** current value; **x:** output voltage (**x=0:** 0-4V $\pm 1.0\%$; **x=3:** 0-5V $\pm 1.0\%$; **x=8:** 0-10V $\pm 1.0\%$); **n:** power supply (**n=2,** $V_{cc} = +12\text{VDC}$; **n=3,** $V_{cc} = +15\text{VDC}$; **n=4,** $V_{cc} = +24\text{VDC}$; **n=5,** $V_{cc} = \pm 12\text{VDC}$; **n=6,** $V_{cc} = \pm 15\text{VDC}$; **n=7,** $V_{cc} = \pm 24\text{VDC}$)

Example 1: CYHCT-EKOV-U1000A-32 Hall Effect DC Current sensor with
Output signal: 0 – 5V DC
Power supply: +12V DC
Rated input current: 0 - 1000A DC (unidirectional)

Example 2: CYHCT-EKOV-B1000A-84 Hall Effect DC Current sensor with
Output signal: 0 – 10V DC
Power supply: +24V DC
Rated input current: -1000A - 0 - +1000A DC (bidirectional)

2) Relation between Input current and output signal

Current Sensor CYHCT-EKOV-U1000A-32	
Input current (A)	Output voltage V_o (V)
0	0
250	1.25
500	2.5
750	3.75
1000	5

Current Sensor CYHCT-EKOV-B1000A-84	
Input current (A)	Output voltage V_o (V)
-1000	0
-750	1.25
-500	2.5
-250	3.75
0	5
250	6.25
500	7.5
750	8.75
1000	10