

Split Core Hall Effect DC Current Sensor CYHCT-EKLC

This Hall Effect current sensor is based on open loop principle and designed with a high galvanic isolation between primary conductor and secondary circuit. It can be used for measurement of DC current etc. The output of the transducer reflects the real wave of the current carrying conductor.

Product Characteristics	Applications
<ul style="list-style-type: none"> • Excellent accuracy • Very good linearity • Less power consumption • Split core window structure • Electrically isolating the output of the transducer from the current carrying conductor • No insertion loss • Current overload capability 	<ul style="list-style-type: none"> • Photovoltaic equipment • Frequency conversion timing equipment • Various power supply • Uninterruptible power supplies (UPS) • Electric welding machines • Electrolyzing and electroplating equipment • Electric powered locomotive • Electric power network monitoring

Technical Data

Primary Nominal DC Current I_r (A)	Primary Current Measuring Range I_p (A)	Output current (mA)	Part number (see application notes on page 3)
10000A	0 ~ ± 10000A	4-20mA	CYHCT-EKLC-U/B10000A-n
20000A	0 ~ ± 20000A		CYHCT-EKLC-U/B20000A-n
30000A	0 ~ ± 30000A		CYHCT-EKLC-U/B30000A-n
40000A	0 ~ ± 40000A		CYHCT-EKLC-U/B40000A-n
50000A	0 ~ ± 50000A		CYHCT-EKLC-U/B50000A-n
60000A	0 ~ ± 60000A		CYHCT-EKLC-U/B60000A-n
70000A	0 ~ ± 70000A		CYHCT-EKLC-U/B70000A-n
80000A	0 ~ ± 80000A		CYHCT-EKLC-U/B80000A-n

(n=2, V_{cc} = +12VDC; n=3, V_{cc} =+15VDC; n=4, V_{cc} =+24VDC; n=5, V_{cc} =±12VDC; n=6, V_{cc} =±15VDC; n=7, V_{cc} =±24VDC; U: unidirectional, B: bidirectional)

Supply Voltage: V_{cc} =+12V, +15V, +24V, ±12V, ±15VDC ± 5%
Current Consumption (V_{cc} =±15VDC): I_c < 50mA + Output current
Isolation Voltage: 6kV, 50/60Hz, 1min

Accuracy at I_r , T_A =25°C (without offset), <1.0% FS
Linearity from 0 to I_r , T_A =25°C, <1.0% FS
Linear Measuring range, 1.2 times of measuring range
Overload capability, 3 times of measuring range
Electric Offset Current, T_A =25°C, 4mA DC or 12mA DC
Thermal Drift of Offset Current, <±0.005mA/°C
Load resistance: 80-450Ω
Response Time at 90% of I_p (f =1k Hz) t_r < 1ms
Frequency Bandwidth (-3dB), f_b = DC-3 kHz
Ambient Operating Temperature, T_A =-25°C ~ +85°C
Ambient Storage Temperature, T_S =-40°C ~ +100°C
Unit Weight:
Standard: Q/320115QHKJ01-2016

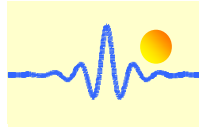

PIN Definition and Dimensions

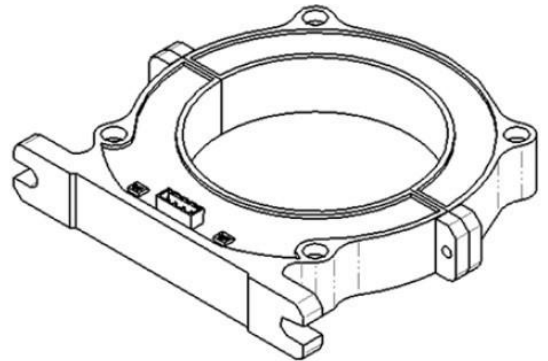
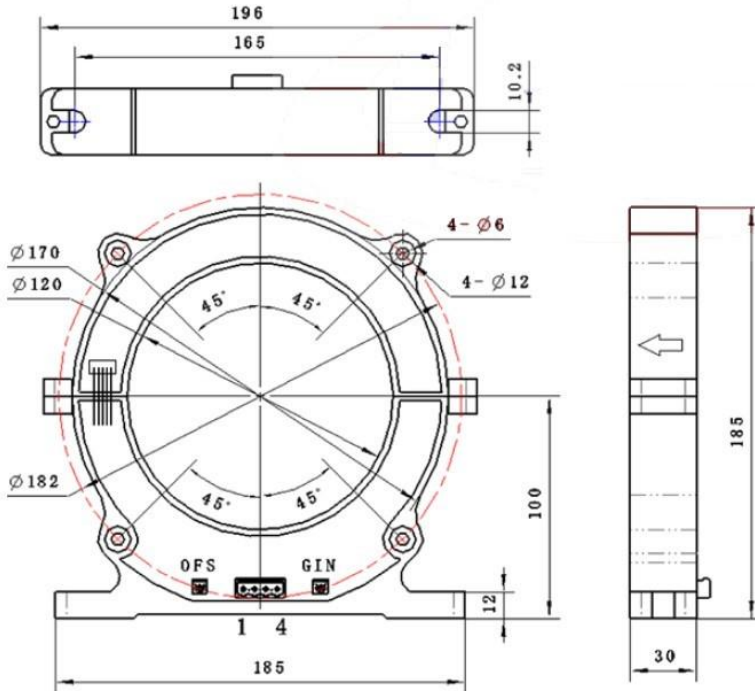

OFS: Offset Adjustment

GIN: Gain Adjustment

Pin arrangement of connector:

1: Vcc 2: -Vcc or GND
3: OUTPUT 4: 0V (GND)

Cable connection:

Red: Vcc
Blue: -Vcc or GND
Yellow: OUTPUT
Black: 0V (GND)

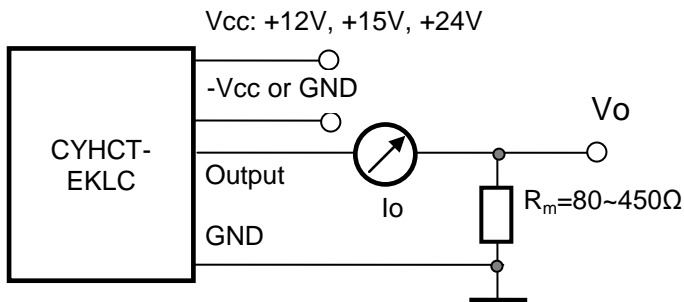

Notes:

1. Connect the terminals of power source, output respectively and correctly, never make wrong connection.
2. Two potentiometers can be adjusted, only if necessary, by turning slowly to the required accuracy with a small screwdriver.
3. The best accuracy can be achieved when the window is fully filled with current carrying conductor.
4. The in-phase output can be obtained when the current direction of current carrying conductor is the same as the direction of arrow marked on the transducer

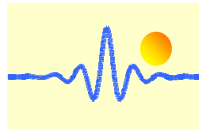

Application Notes

1) Part number CYHCT-EKLC-U/BxxxxA-n

U: unidirectional input current; **B:** bidirectional input current; **xxxx:** current value; **n:** power supply (**n=2**, $V_{cc}=+12VDC$; **n=3**, $V_{cc}=+15VDC$; **n=4**, $V_{cc}=+24VDC$; **n=5**, $V_{cc}=\pm 12VDC$; **n=6**, $V_{cc}=\pm 15VDC$; **n=7**, $V_{cc}=\pm 24VDC$)

Example 1: CYHCT-EKLC-U1000A-5 Hall Effect DC Current sensor with
Output signal: 4mA - 20mA DC
Power supply: +24V DC
Rated input current: 0 - 1000A DC (unidirectional)

Example 2: CYHCT-EKLC-B1000A-3 Hall Effect DC Current sensor with
Output signal: 4mA – 12mA - 20mA DC
Power supply: +12V DC
Rated input current: -1000A - 0 - +1000A DC (bidirectional)

2) Relation between Input current and output signal

Current Sensor CYHCT-EKLC-U1000A-5		
Input current (A)	Output current I_o (mA)	Output voltage V_o (V) (Measuring resistance $R_m=250\Omega$)
0	4	1
250	8	2
500	12	3
750	16	4
1000	20	5

Current Sensor CYHCT-EKLC-B1000A-3		
Input current (A)	Output current I_o (mA)	Output voltage V_o (V) (Measuring resistance $R_m=250\Omega$)
-1000	4	1
-750	6	1.5
-500	8	2
-250	10	1.5
0	12	3
250	14	3.5
500	16	4
750	18	4.5
1000	20	5