

Hall Effect DC Current Sensor CYHCT-D6C

This Hall Effect current sensor is based on open loop principle and designed with a solid core and a high galvanic isolation between primary conductor and secondary circuit. It can be used for measurement of DC current etc. The output of the transducer reflects the real wave of the current carrying conductor.

Product Characteristics	Applications
<ul style="list-style-type: none"> • Excellent accuracy • Very good linearity • Less power consumption • Window structure • Electrically isolating the output of the transducer from the current carrying conductor • No insertion loss • Current overload capability 	<ul style="list-style-type: none"> • Photovoltaic equipment • Frequency conversion timing equipment • Various power supply • Uninterruptible power supplies (UPS) • Electric welding machines • Transformer substation • Numerical controlled machine tools • Electric powered locomotive • Microcomputer monitoring • Electric power network monitoring

Electrical Data

Primary Nominal DC Current I_r (A)	Measuring Range (A)	DC Output Current (mA)	Part number (see application notes on page 4)
50	0 ~ ±50A	4-20 ±1.0%	CYHCT-D6C-U/B500A-n
100	0 ~ ±100A		CYHCT-D6C-U/B100A-n
200	0 ~ ±200A		CYHCT-D6C-U/B200A-n
300	0 ~ ±300A		CYHCT-D6C-U/B300A-n
400	0 ~ ±400A		CYHCT-D6C-U/B400A-n
500	0 ~ ±500A		CYHCT-D6C-U/B500A-n
600	0 ~ ±600A		CYHCT-D6C-U/B600A-n
700	0 ~ ±700A		CYHCT-D6C-U/B700A-n
800	0 ~ ±800A		CYHCT-D6C-U/B800A-n
900	0 ~ ±900A		CYHCT-D6C-U/B900A-n
1000	0 ~ ±1000A		CYHCT-D6C-U/B1000A-n

(U: unidirectional input current; B: bidirectional input current, please give U or B in Part number)
(n=3, V_{cc} = +12VDC ±5%; n=4, V_{cc} =+15VDC ±5%; n=5, V_{cc} =+24VDC±5%)

Supply Voltage	V_{cc} =+12V, +15V, +24VDC ± 5%
Current Consumption	I_c < 25mA + Output current
Galvanic isolation, 50/60Hz, 1min:	2.5kV
Isolation resistance @ 500 VDC	> 500 MΩ

Accuracy and Dynamic performance data

Accuracy at I_r , $T_A=25^\circ\text{C}$ (without offset),	<1.0%
Linearity from 0 to I_r , $T_A=25^\circ\text{C}$,	E_L <1.0% FS
Electric Offset Current, $T_A=25^\circ\text{C}$,	4mA DC or 12mA DC
Thermal Drift of Offset Current,	<±0.005mA/°C
Response Time at 90% of I_P	t_r < 1ms
Load resistance:	80-450Ω
Frequency Bandwidth (-3dB),	f_b = DC - 20 kHz
Case Material:	PBT

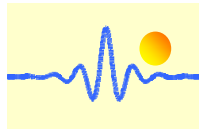

General Data

Ambient Operating Temperature,
Ambient Storage Temperature,

$T_A = -25^{\circ}\text{C} \sim +85^{\circ}\text{C}$
 $T_S = -40^{\circ}\text{C} \sim +100^{\circ}\text{C}$

PIN Definition and Dimensions

CYHCT-D6C-xxxx

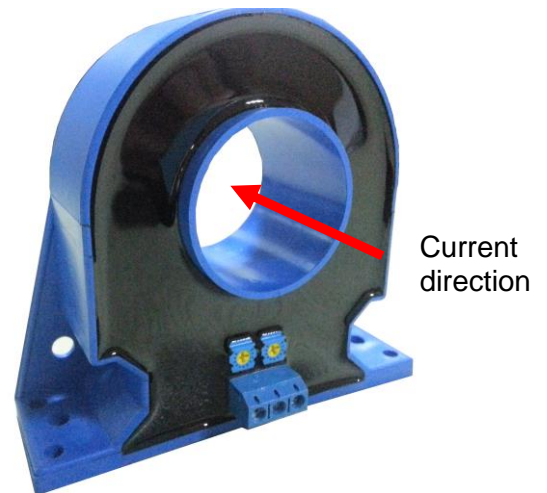
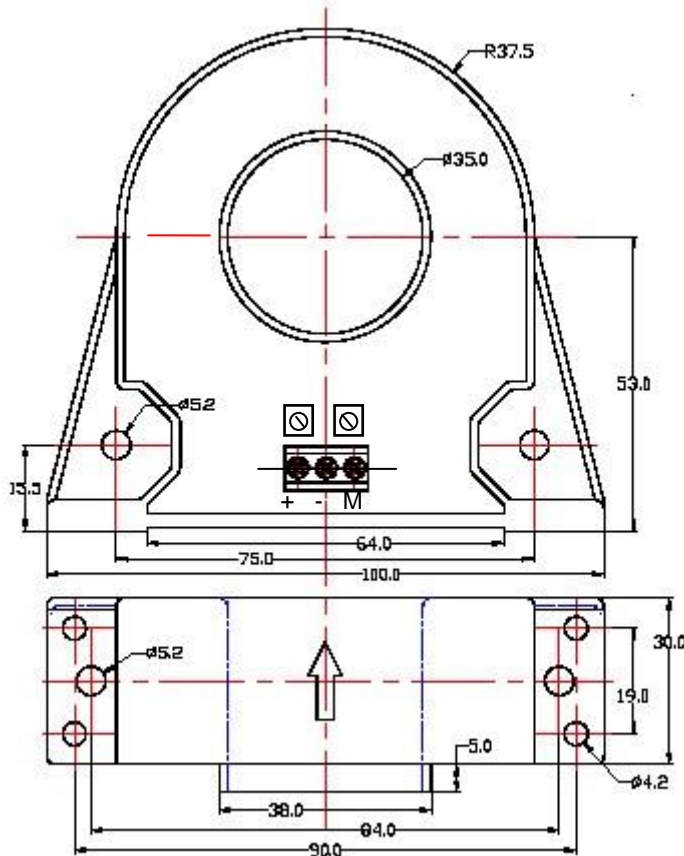

Terminal Arrangement

- 1(+): Vcc
- 2(-): GND
- 3(M): Output

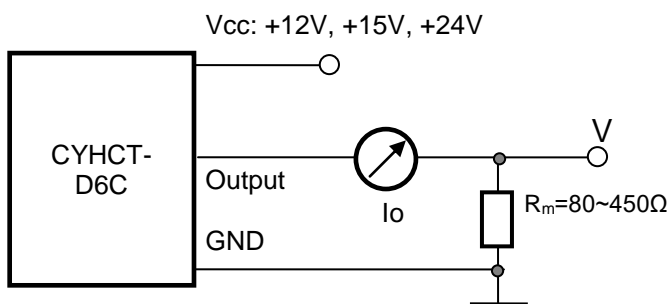

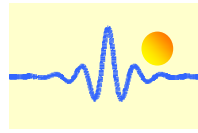

CYHCS-D6C-xxxx

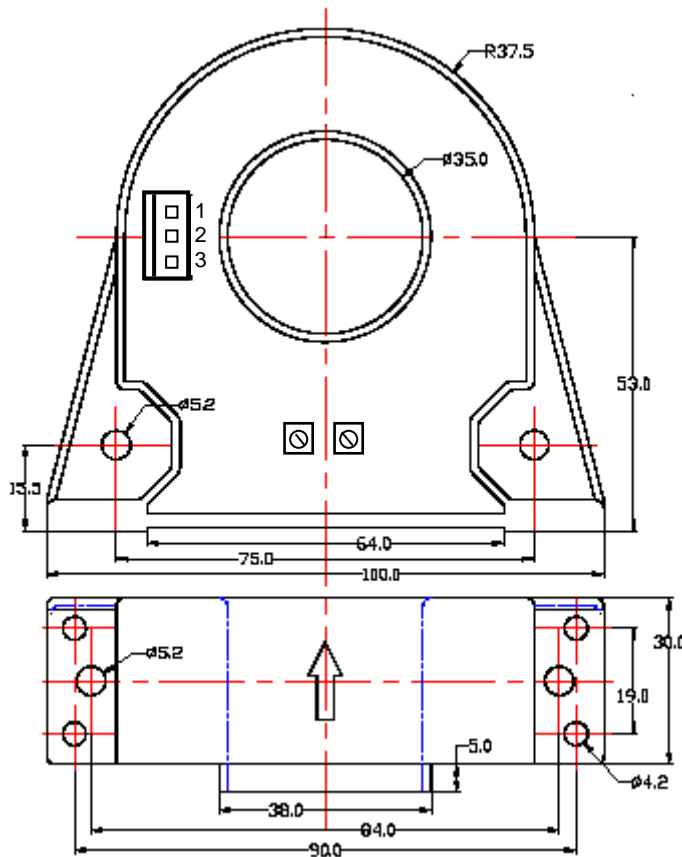

Terminal Arrangement

- 1: Vcc
- 2: GND
- 3: Output

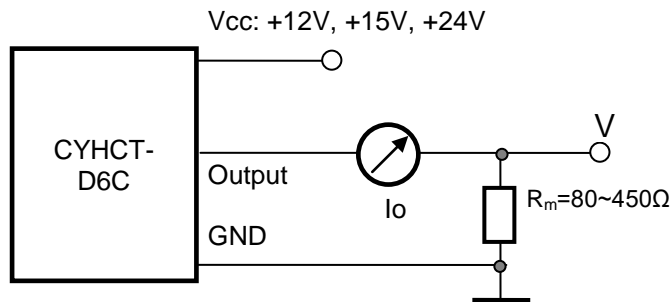

Notes:

1. Connect the terminals of power source, output respectively and correctly, never make wrong connection.
2. Two potentiometers can be adjusted, only if necessary, by turning slowly to the required accuracy with a small screwdriver.
3. The best accuracy can be achieved when the window is fully filled with bus-bar (current carrying conductor).
4. The in-phase output can be obtained when the direction of current of current carrying conductor is the same as the direction of arrow marked on the transducer

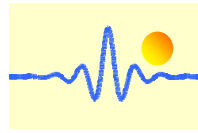

Application Notes

1) Part number CYHCT-D6C-U/BxxxA-n

U: unidirectional input current; **B:** bidirectional input current; **xxx:** current value; **n:** power supply (**n=3**, $V_{cc} = +12VDC \pm 5\%$; **n=4**, $V_{cc} = +15VDC \pm 5\%$; **n=5**, $V_{cc} = +24VDC \pm 5\%$)

Example 1: CYHCT-D6C-U100A-5 Hall Effect DC Current sensor with
Output signal: 4mA - 20mA DC
Power supply: +24V DC
Rated input current: 0 - 100A DC (unidirectional)

Example 2: CYHCT-D6C-B100A-3 Hall Effect DC Current sensor with
Output signal: 4mA – 12mA - 20mA DC
Power supply: +12V DC
Rated input current: -100A - 0 - +100A DC (bidirectional)

2) Relation between Input current and output signal

Current Sensor CYHCT-D6C-U100A-5		
Input current (A)	Output current I_o (mA)	Output voltage V_o (V) (Measuring resistance $R_m=250\Omega$)
0	4	1
25	8	2
50	12	3
75	16	4
100	20	5

Current Sensor CYHCT-D6C-B100A-3		
Input current (A)	Output current I_o (mA)	Output voltage V_o (V) (Measuring resistance $R_m=250\Omega$)
-100	4	1
-75	6	1.5
-50	8	2
-25	10	1.5
0	12	3
25	14	3.5
50	16	4
75	18	4.5
100	20	5