

Hall Effect DC Current Sensor CYHCT-C4TV

This Hall Effect current sensor is based on open loop principle and designed with a solid core and a high galvanic isolation between primary conductor and secondary circuit. It can be used for measurement of DC current etc. The output of the transducer reflects the real wave of the current carrying conductor.

Product Characteristics	Applications
<ul style="list-style-type: none"> • Excellent accuracy • Very good linearity • Light in weight • Less power consumption • Window structure • Electrically isolating the output of the transducer from the current carrying conductor • No insertion loss • Current overload capability 	<ul style="list-style-type: none"> • Photovoltaic equipment • Frequency conversion timing equipment • Various power supply • Uninterruptible power supplies (UPS) • Electric welding machines • Numerical controlled machine tools • Electrolyzing and electroplating equipments • Electric powered locomotive • Microcomputer monitoring • Electric power network monitoring

Electrical Data/Input

Primary Nominal DC Current I_r (A)	Primary Current Measuring Range I_p (A)	DC Output Voltage (V)	Part number (see application notes on page 3)
50A	0 ~ ±50A	x=0: 0-4V ±1.0% x=3: 0-5V ±1.0% x=8: 0-10V ±1.0%	CYHCT-C4TV-U/B50A-xn
100A	0 ~ ±100A		CYHCT-C4TV-U/B100A-xn
200A	0 ~ ±200A		CYHCT-C4TV-U/B200A-xn
300A	0 ~ ±300A		CYHCT-C4TV-U/B300A-xn
400A	0 ~ ±400A		CYHCT-C4TV-U/B400A-xn
500A	0 ~ ±500A		CYHCT-C4TV-U/B500A-xn
600A	0 ~ ±600A		CYHCT-C4TV-U/B600A-xn
700A	0 ~ ±700A		CYHCT-C4TV-U/B700A-xn
800A	0 ~ ±800A		CYHCT-C4TV-U/B800A-xn
1000A	0 ~ ±1000A		CYHCT-C4TV-U/B1000A-xn

(n=2, V_{cc} = +12VDC; n=3, V_{cc} =+15VDC; n=4, V_{cc} =+24VDC, U: unidirectional, B: bidirectional)

Supply Voltage:	V_{cc} =+12V, +15V, +24V± 5%
Current Consumption	I_c < 25mA
Isolation Voltage	2.5kV, 50/60Hz, 1min
Output Voltage at I_r , $T_A=25^\circ\text{C}$:	V_{out} =0- 4V, 0-5V, 0-10VDC
Output Impedance:	R_{out} < 150Ω
Load Resistor:	R_L > 10kΩ

Accuracy

Accuracy at I_r , $T_A=25^\circ\text{C}$,	X <1.0% FS
Linearity from 0 to I_r , $T_A=25^\circ\text{C}$,	E_L <1.0% FS
Electric Offset Voltage, $T_A=25^\circ\text{C}$,	V_{oe} <50mV
Magnetic Offset Voltage ($I_r \rightarrow 0$)	V_{om} <±20mV
Thermal Drift of Offset Voltage,	V_{ot} <±1.0mV/°C
Thermal Drift (-10°C to 50°C),	T.C. < ±0.1% /°C
Response Time at 90% of I_p ($f=1\text{kHz}$)	t_r < 1ms
Frequency Bandwidth (-3dB),	f_b = DC - 20 kHz
Case Material:	PBT

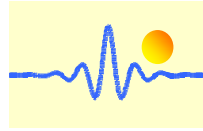

General Data

Ambient Operating Temperature,
Ambient Storage Temperature,

$T_A = -25^{\circ}\text{C} \sim +85^{\circ}\text{C}$
 $T_S = -40^{\circ}\text{C} \sim +100^{\circ}\text{C}$

PIN Definition and Dimensions

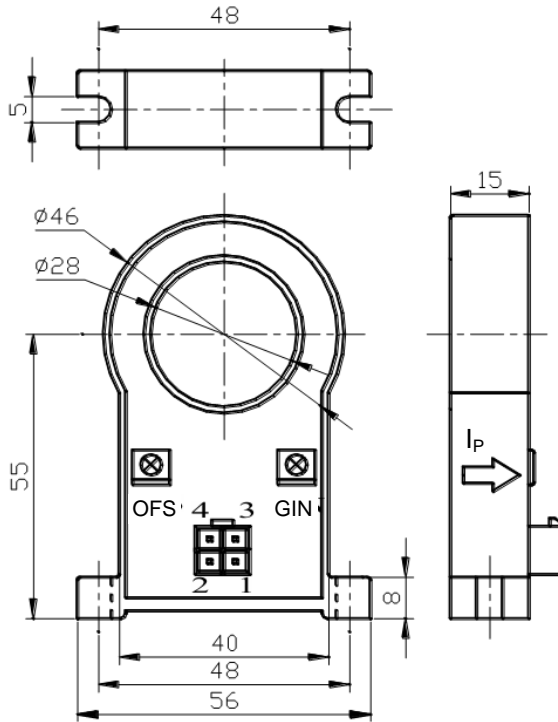

1(G): GND
2(G): GND
3(O): Output
4(+): Vcc

Connection

OFS: Offset Adjustment
GIN: Gain Adjustment

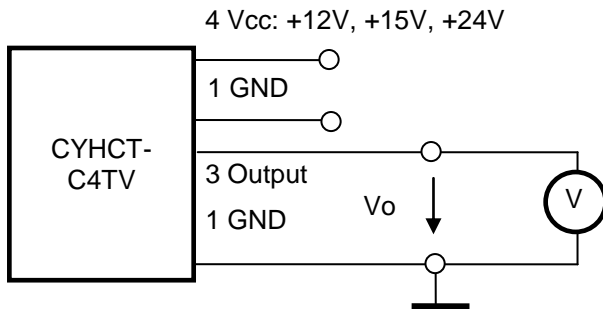

Notes:

1. Connect the terminals of power source, output respectively and correctly, never make wrong connection.
2. Two potentiometers can be adjusted, only if necessary, by turning slowly to the required accuracy with a small screwdriver.
3. The best accuracy can be achieved when the window is fully filled with bus-bar (current carrying conductor).
4. The in-phase output can be obtained when the direction of current of current carrying conductor is the same as the direction of arrow marked on the transducer

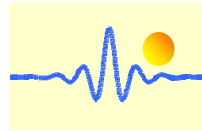

Application Notes

1) Part number CYHCT-C4TV-U/BxxxA-xn

U: unidirectional input current; **B:** bidirectional input current; **xxx:** current value; **x:** output voltage (**x=0:** 0-4V $\pm 1.0\%$; **x=3:** 0-5V $\pm 1.0\%$; **x=8:** 0-10V $\pm 1.0\%$); **n:** power supply (**n=2,** Vcc= +12VDC; **n=3,** Vcc =+15VDC; **n=4,** Vcc =+24VDC,)

Example 1: CYHCT-C4TV-U100A-32 Hall Effect DC Current sensor with
Output signal: 0 – 5V DC
Power supply: +12V DC
Rated input current: 0 - 100A DC (unidirectional)

Example 2: CYHCT-C4TV-B100A-84 Hall Effect DC Current sensor with
Output signal: 0 – 10V DC
Power supply: +24V DC
Rated input current: -100A - 0 - +100A DC (bidirectional)

2) Relation between Input current and output signal

Current Sensor CYHCT-C4TV-U100A-32	
Input current (A)	Output voltage Vo (V)
0	0
25	1.25
50	2.5
75	3.75
100	5

Current Sensor CYHCT-C4TV-B100A-84	
Input current (A)	Output voltage Vo (V)
-100	0
-75	1.25
-50	2.5
-25	3.75
0	5
25	6.25
50	7.5
75	8.75
100	10