

AC/DC Open Loop Hall Current Sensor Module CYHCS950

The CYHCS950 series is an open-loop current sensor module based on the Hall effect principle, providing a more economical and accurate solution for AC or DC current sensing in industrial, commercial and communication systems. It can be used for motor control, load detection and load management, power supplies and DC-DC converters, photovoltaic inverters, UPS, overcurrent protection and low and medium power inverter current detection applications.

The CYHCS950 consists of a high precision, low noise, low temperature drift linear Hall IC, a magnetic core and a low resistance (0.12mΩ) current conductor path (located near the die surface). The applied current flowing through this conductor path generates a magnetic field, which is converted by the Hall IC into a voltage output proportional to the input current.

The CYHCS950 output voltage is provided by a low offset, chopper-stabilized BCD Hall IC that is factory calibrated internally for different current ranges. The output of the chip has a positive slope (>VOQ) as the applied external current flows through the conduction path (from pin 4 to pin 5). The internal resistance of the conduction path is typically 120μΩ, allowing for low power consumption. The terminals of the conduction path (pins 4 and 5) are electrically isolated from the signal terminals (pins 1 to 3). This allows the CYHCS950 current sensor module to be used in current sensing applications without the need for other expensive isolation techniques.

All pins of CYHCS950 series are tinned and the package material is lead-free and RoHS compliant.

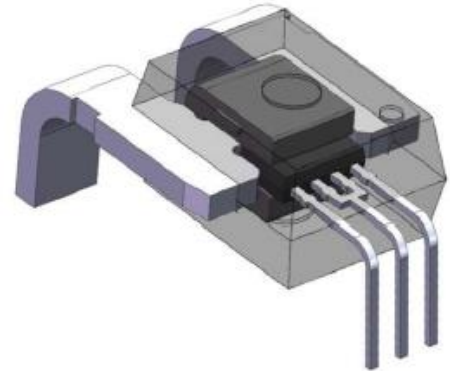

Features

- Static output bias voltage of 2.5V or 50% V_{CC}
- Measurement range 50A/100A/150A /200A
- Isolation voltage 990VDC or 680V RMS
- High frequency bandwidth: 100kHz
- Output response time: 4μs (typical)
- Temperature range -40°C to 125°C
- Extremely stable static output voltage
- Low noise analog signal; high immunity to interference
- High resistance to mechanical stress, magnetic field parameters are not shifted by external pressure,
- ESD (HBM) 5kV
- ROHS approved: (EU) 2015 / 863

Applications

- Electric Vehicles
- Inverter current detection
- Motor phase current detection (motor control)
- Photovoltaic inverters
- Battery load detection systems
- Current transformers
- Switching power supplies
- Overload protection devices
- Inverter speed control equipment
- Uninterruptible Power Supplies (UPS)
- Electrolytic and plating equipment
- Charger and converter

Absolute maximum rating

Supply voltage V_{CC}	6V
Output voltage V_{OUT}	$V_{CC} - 0.25V$
Output source current, I_{OUT}	80mA
Output sink current, I_{OUT}	40mA
Operating temperature range, T_A	-40°C ~ +125°C
Storage temperature range, T_S	-55°C ~ +165°C
Maximum junction temperature, T_J	165°C
Transient inrush current at the current input	100A (IP 1 Pulse 100ms)

Exceeding the limit parameters during use may cause the current sensor module to function unstably and may damage it if left in this environment for a long period of time.

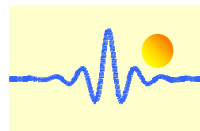

Static protection

Human Body Model (HBM) testing according to: Standard EIA/JESD22-A114-B HBM

Parameter	Symbol	Standard	Min	max	Unit
Human model HBM electrostatic stress voltage	V _{ESD}	JEDEC JS-001-2017	-5000	5000	V

Electric parameters

Parameters	Symbo	Test conditions	min	Typ.	Max.	unit
Supply voltage	V _{CC}	operation	4.5	5.0	5.5	V
Supply current	I _{CC}	T _A =25°C, no load on output	9.18	11.18	13.18	mA
Built-in band width (-3dB)	BW	Small signal: -3dB, C _L =1nF, T _A =25°C	-	65	-	kHz
Power-up time	T _{PO}	T _A =25°C, C _L =1nF, sensitivity: 2mV/G, constant mag. field: 400Gs		100		µs
Temperature compensated power-up time	T _{TC}	T _A =125°C, C _L =1nF, sensitivity: 2mV/G, constant mag. field: 400Gs		300		µs
Undervoltage lockout threshold (T _A =25°C)	V _{UVLOH}	voltage rises, IC starts to operate	-	4.1	-	V
	V _{UVLOL}	voltage drops, IC stops	-	3.8	-	V
Reset voltage	V _{PORH}	T _A =25°C, V _{CC} rises	-	4.1	-	V
	V _{PORL}	T _A =25°C, V _{CC} drops	-	3.8	-	V
Power-on reset release time	T _{PORR}	T _A =25°C, V _{CC} rises		10		µs
Max. current (source)	I _{SCLP}			80		mA
Maximum current (sink)	I _{SCLN}			40		mA
Analog output saturation low	V _{OL}	R _L >=4.7kΩ		0.5		V
Analog output saturation high	V _{OH}	R _L >=4.7kΩ	V _{CC} -	-	4.97	V
Output load capacitance	C _L	V _{OUT} to GND	-	0.5	1	nF
Output load resistance	R _L	V _{OUT} to GND		10		kΩ
		V _{OUT} to V _{CC}		10		kΩ
Output resistance	R _{OUT}			9		Ω
Rise time	T _R	T _A =25°C, C _L =1nF, sensitivity: 2mV/G, constant mag. field: 400Gs		5.5		µs
Transfer delay time	T _{PD}			4.5		µs
Response time	T _{RESP}			4	5	µs
Noise	V _N	T _A =25°C, C _L =1nF, sensitivity: 2mV/G, B _{wf} = B _{wi}		14.1		mVp-p
Resistance of current input Terminals	R _P			1.5	1.8	mΩ
Linearity error	E _{lin}	T _A =25°C, C _L =1nF, sensitivity: 2mV/G, B _{wf} = B _{wi}		0.4		%
Static operating point	V _{OS}		2.485	2.50	2.515	V

Isolation characteristics

Parameter	Symbol	Test conditions	Rated value	Unit
Dielectric strength	V _{ISO}	Test 60 seconds	4800	V _{rms}
Isolation working voltage	V _{WFSI}	Single isolation	990	V _{DC} /V _{pk}
			680	V _{rms}
Electrical clearance	D _{CL}	Min. air distance from input terminal to output terminal	5.2	mm
Creepage distance	D _{CR}	Min. distance from input terminal to output terminal along the plastisol	7.2	mm

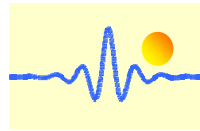

Measuring range

Parameter	Symbol	Part no.	Min.	typ	Max.	unit
Measuring range	I _P	CYHCS950-50B5	-50		50	A
		CYHCS950-100B5	-100		100	A
		CYHCS950-150B5	-150		150	A
		CYHCS950-200B5	-200		200	A

CYHCS950-50B5 technical parameters

parameter	symbol	Test conditions	Min.	typ	Max.	unit
Current Meas.	I _P		-50		50	A
Sensitivity	Sens	I _p full scale, 5ms applied, T _A =25°C		40		mV/A
Static output voltage	V _{OQ}		0.5V _{CC} , or 2.5			V
Output noise	V _{NOISE(PP)}	T _A =25°C, 10nF capacitor between V _{OUT} and GND	-	12	-	mV
Non-linear error	E _{LIN}	I _p full scale, 5ms applied, T _A =25°C		±1.0		%FS
Zero current output error	V _{OE(T_A)}	I _P =0A, T _A =25°C		±7.0		mV
	V _{OE(T_{OP})HT}	I _P =0A, T _{OP} = 25°C~125°C		±15		mV
	V _{OE(T_{OP})LT}	I _P =0A, T _{OP} = -40°C~25°C		±18		mV
Sensitivity error	E _{SEN}	I _P =±50A, T _A = 25°C		±1.2		%
		I _P =±50A, T _{OP} = 25°C~125°C		±2.3		%
		I _P =±50A, T _{OP} = -40°C~25°C		±2.3		%
Total Measuring Error	E _{TOT} (HT)	I _p full scale, 5ms, T _{OP} =25°C~125°C		±2.5		%
	E _{TOT} (LT)	I _p full scale, 5ms, T _{OP} =-40°C~25°C		±2.5		%

CYHCS950-100B5 technical parameters

parameter	symbol	Test conditions	Min.	typ	Max.	unit
Current Meas.	I _P		-100		100	A
Sensitivity	Sens	I _p full scale, 5ms applied, T _A =25°C		20		mV/A
Static output voltage	V _{OQ}		0.5V _{CC} , or 2.5			V
Output noise	V _{NOISE(PP)}	T _A =25°C, 10nF capacitor between V _{OUT} and GND	-	8	-	mV
Non-linear error	E _{LIN}	I _p full scale, 5ms applied, T _A =25°C		±1.0		%FS
Zero current output error	V _{OE(T_A)}	I _P =0A, T _A =25°C		±5.0		mV
	V _{OE(T_{OP})HT}	I _P =0A, T _{OP} = 25°C~125°C		±20		mV
	V _{OE(T_{OP})LT}	I _P =0A, T _{OP} = -40°C~25°C		±20		mV
Sensitivity error	E _{SEN}	I _P =±100A, T _A = 25°C		±1.2		%
		I _P =±100A, T _{OP} = 25°C~125°C		±2.3		%
		I _P =±100A, T _{OP} = -40°C~25°C		±2.3		%
Total Measuring Error	E _{TOT} (HT)	I _p full scale, 5ms, T _{OP} =25°C~125°C		±2.5		%
	E _{TOT} (LT)	I _p full scale, 5ms, T _{OP} =-40°C~25°C		±2.5		%

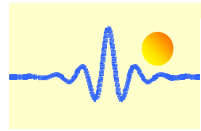

CYHCS950-150B5 technical parameters

parameter	symbol	Test conditions	Min.	typ	Max.	unit
Current Meas.	I_P		-150		150	A
Sensitivity	Sens	I_P full scale, 5ms applied, $T_A=25^\circ\text{C}$		13.3		mV/A
Static output voltage	V_{OQ}		0.5V _{CC} , or 2.5			V
Output noise	$V_{NOISE(PP)}$	$T_A=25^\circ\text{C}$, 10nF capacitor between V_{OUT} and GND	-	6	-	mV
Non-linear error	E_{LIN}	I_P full scale, 5ms applied, $T_A=25^\circ\text{C}$		± 1.0		%FS
Zero current output error	$V_{OE}(T_A)$	$I_P=0A, T_A=25^\circ\text{C}$		± 5.0		mV
	$V_{OE}(T_{OP})HT$	$I_P=0A, T_{OP}= 25^\circ\text{C}\sim 125^\circ\text{C}$		± 20		mV
	$V_{OE}(T_{OP})LT$	$I_P=0A, T_{OP}= -40^\circ\text{C}\sim 25^\circ\text{C}$		± 20		mV
Sensitivity error	E_{SEN}	$I_P=\pm 150A, T_A= 25^\circ\text{C}$		± 1.2		%
		$I_P=\pm 150A, T_{OP}= 25^\circ\text{C}\sim 125^\circ\text{C}$		± 2.3		%
		$I_P=\pm 150A, T_{OP}= -40^\circ\text{C}\sim 25^\circ\text{C}$		± 2.3		%
Total Measuring Error	$E_{TOT}(HT)$	I_P full scale, 5ms, $T_{OP}=25^\circ\text{C}\sim 125^\circ\text{C}$		± 2.5		%
	$E_{TOT}(LT)$	I_P full scale, 5ms, $T_{OP}=-40^\circ\text{C}\sim 25^\circ\text{C}$		± 2.5		%

CYHCS950-200B5 technical parameters

parameter	symbol	Test conditions	Min.	typ	Max.	unit
Current Meas.	I_P		-200		200	A
Sensitivity	Sens	I_P full scale, 5ms applied, $T_A=25^\circ\text{C}$		10		mV/A
Static output voltage	V_{OQ}		0.5V _{CC} , or 2.5			V
Output noise	$V_{NOISE(PP)}$	$T_A=25^\circ\text{C}$, 10nF capacitor between V_{OUT} and GND	-	3	-	mV
Non-linear error	E_{LIN}	I_P full scale, 5ms applied, $T_A=25^\circ\text{C}$		± 1.0		%FS
Zero current output error	$V_{OE}(T_A)$	$I_P=0A, T_A=25^\circ\text{C}$		± 5.0		mV
	$V_{OE}(T_{OP})HT$	$I_P=0A, T_{OP}= 25^\circ\text{C}\sim 125^\circ\text{C}$		± 20		mV
	$V_{OE}(T_{OP})LT$	$I_P=0A, T_{OP}= -40^\circ\text{C}\sim 25^\circ\text{C}$		± 20		mV
Sensitivity error	E_{SEN}	$I_P=\pm 200A, T_A= 25^\circ\text{C}$		± 1.2		%
		$I_P=\pm 200A, T_{OP}= 25^\circ\text{C}\sim 125^\circ\text{C}$		± 2.3		%
		$I_P=\pm 200A, T_{OP}= -40^\circ\text{C}\sim 25^\circ\text{C}$		± 2.3		%
Total Measuring Error	$E_{TOT}(HT)$	I_P full scale, 5ms, $T_{OP}=25^\circ\text{C}\sim 125^\circ\text{C}$		± 2.5		%
	$E_{TOT}(LT)$	I_P full scale, 5ms, $T_{OP}=-40^\circ\text{C}\sim 25^\circ\text{C}$		± 2.5		%

Overcurrent capability

Parameter	Symbol	Test Conditions	Rated Value	Unit
Overcurrent capability	I_{POC}	$T_A=25^\circ\text{C}$, duration 1 second, duty cycle 1%	1200	A
		$T_A=85^\circ\text{C}$, duration 1 second, duty cycle 1%	900	A
		$T_A=125^\circ\text{C}$, duration 1 second, duty cycle 1%	600	A

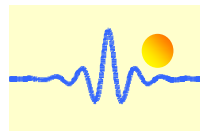

Functional diagram

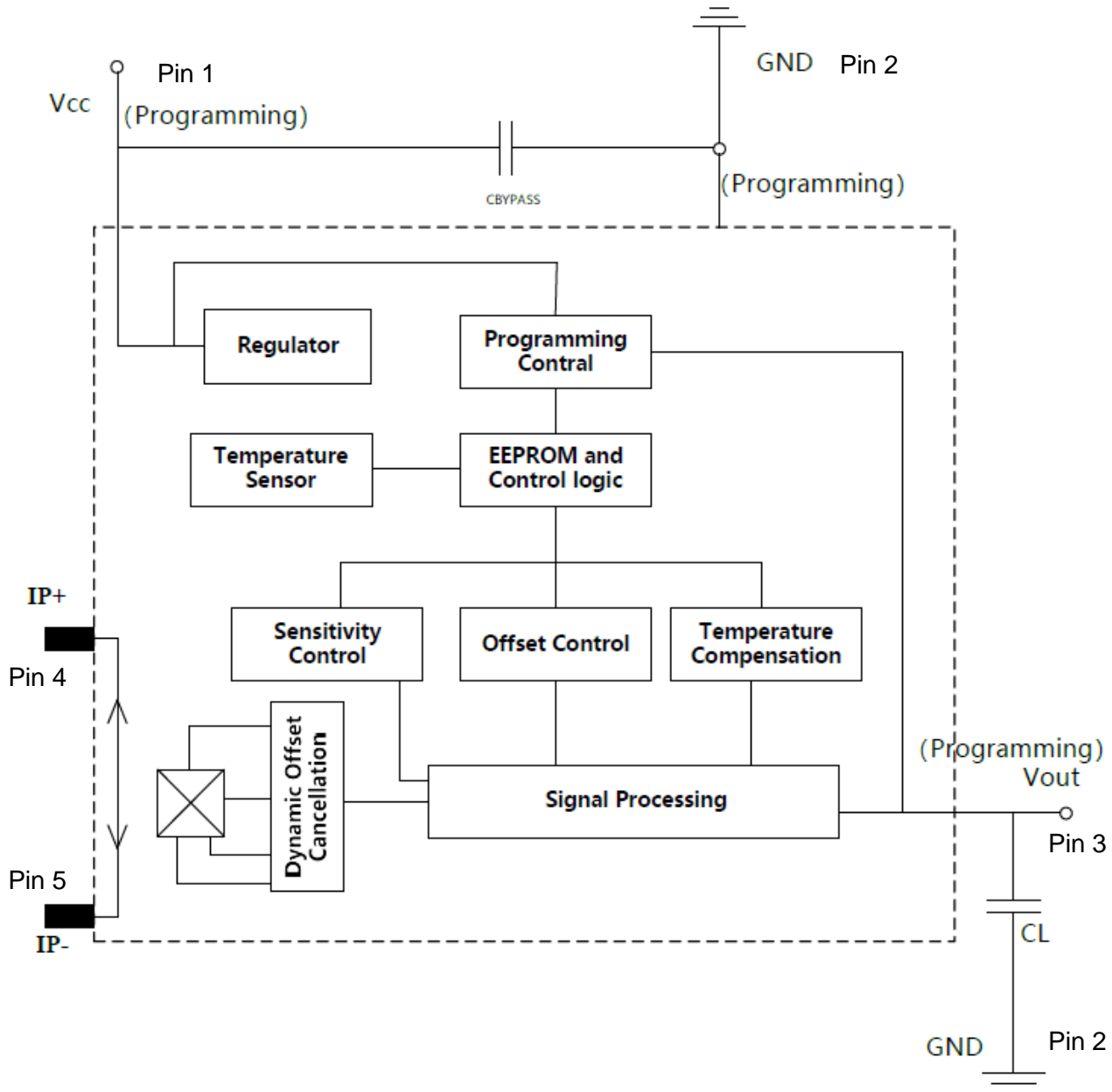

Pin arrangement

Pin	No.	Function
1	Vcc	Power supply / programming pin
2	GND	Ground
3	V _{OUT}	Signal Out / Programming pin
4	IP+	Positive current input
5	IP-	Negative current input

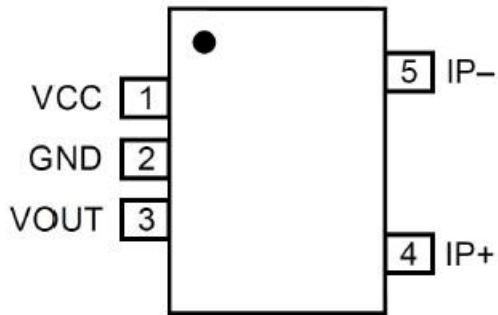
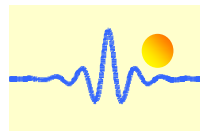

Typical application circuit

The sensor CYHCS950 outputs an analogue signal V_{OUT} which varies linearly with the bidirectional AC or DC primary current over a specified range. The C_F is used to optimize noise management and its value depends on the application.

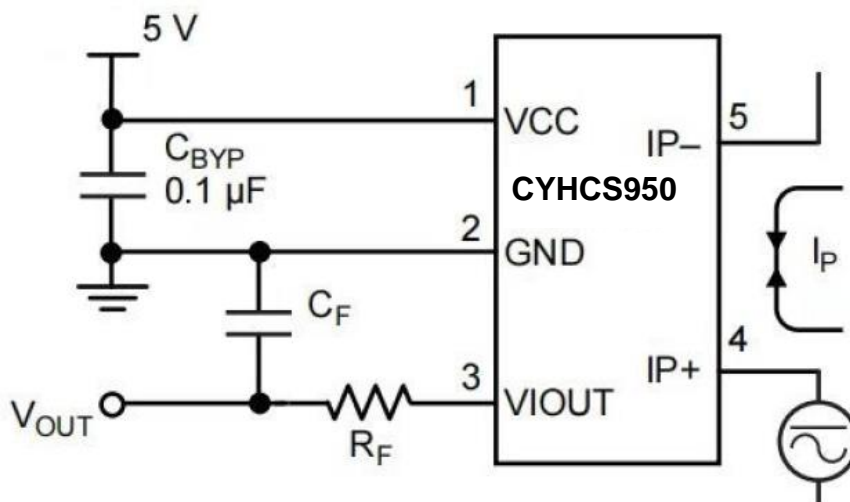

Application circuit of a 3-phase motor controller

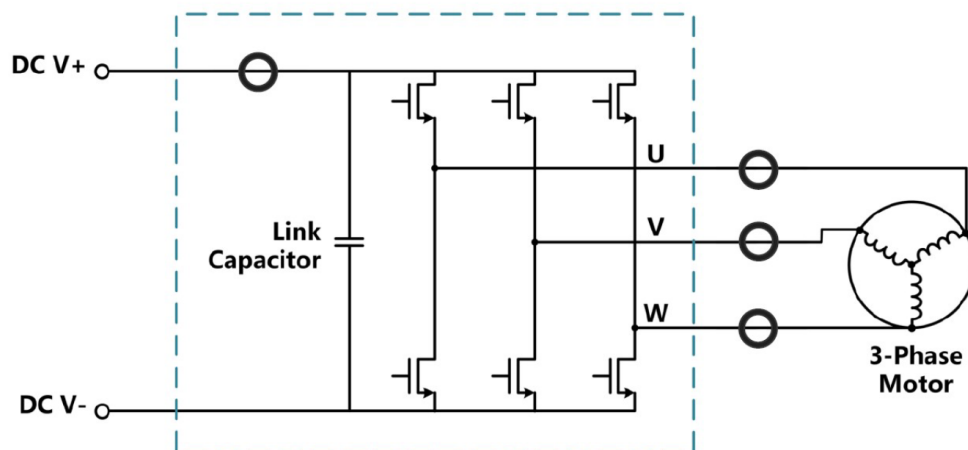

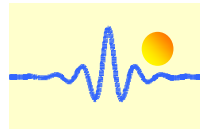

Package Information

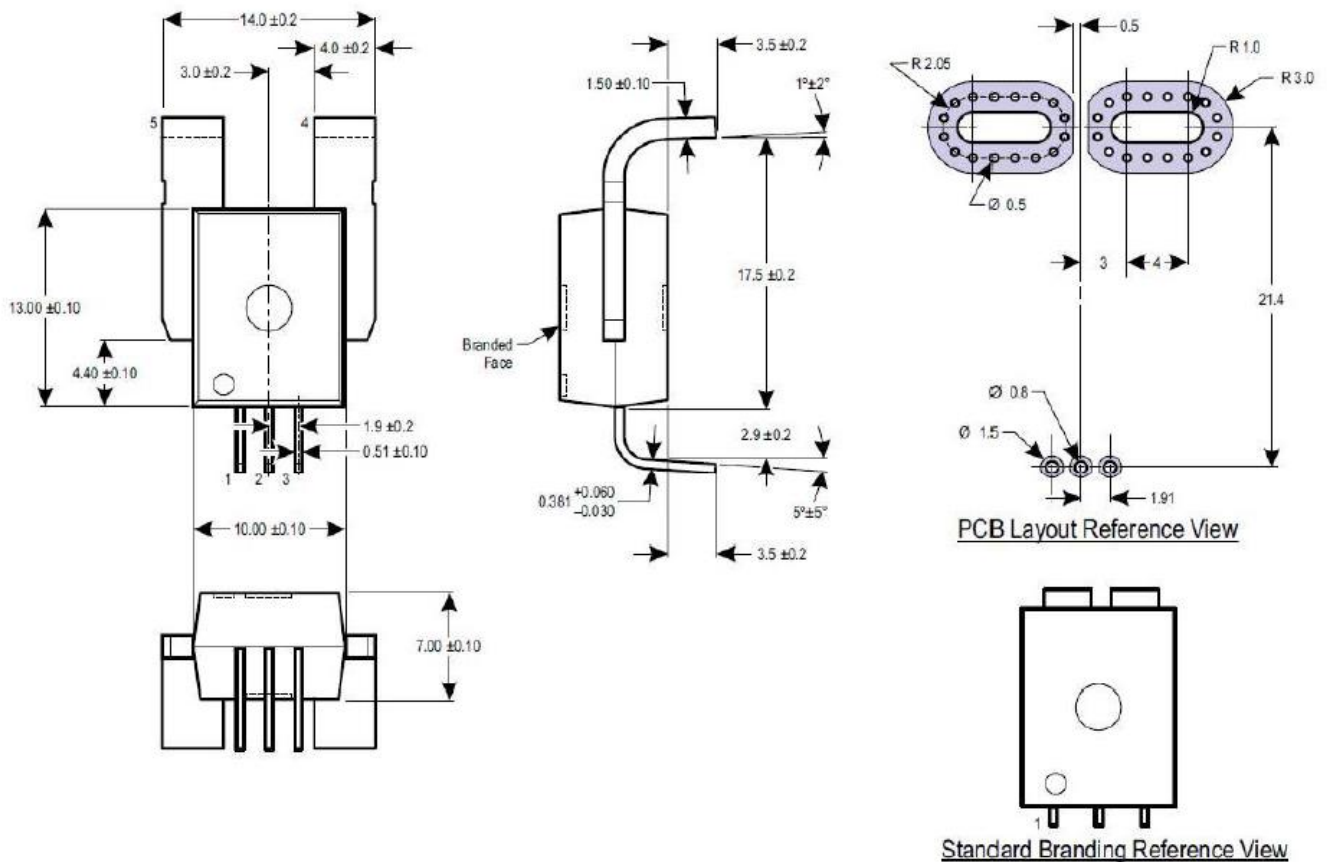

Notes

- Hall chips are sensitive devices, so special care should be taken to protect them from static electricity during use and storage.
- The mechanical stress applied to the device housing and leads should be minimized during soldering and use.
- It is recommended that the soldering temperature does not exceed 350°C and the duration does not exceed 5 seconds.
- To ensure the safety and stability of Hall ICs, long-term use outside the parameter range is not recommended.

Ordering Information

Part number	Sensitivity range	package	packing	Operating temperature range
CYHCS950-50B5	40mV/A	CB-2-3	40 pcs/tube	-40°C ~ 125°C
CYHCS950-100B5	20mV/A	CB-2-3	40 pcs/tube	-40°C ~ 125°C
CYHCS950-150B5	13.3mV/A	CB-2-3	40 pcs/tube	-40°C ~ 125°C
CYHCS950-200B5	10.0mV/A	CB-2-3	40 pcs/tube	-40°C ~ 125°C

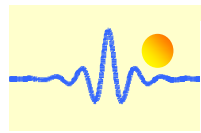

Parameter Definitions

Power on Time - TPO

When the power supply rises to the operating voltage, the IC needs a limited time to power up the internal components before responding to the input current.

Power-up time: the time taken for the power supply to reach the minimum operating voltage $V_{CC_{MIN}}$ is t_1 ; in the case of an applied current under test, the time taken for the output to reach 90% of its stable value t_2 . The difference between the two times is the power-up time.

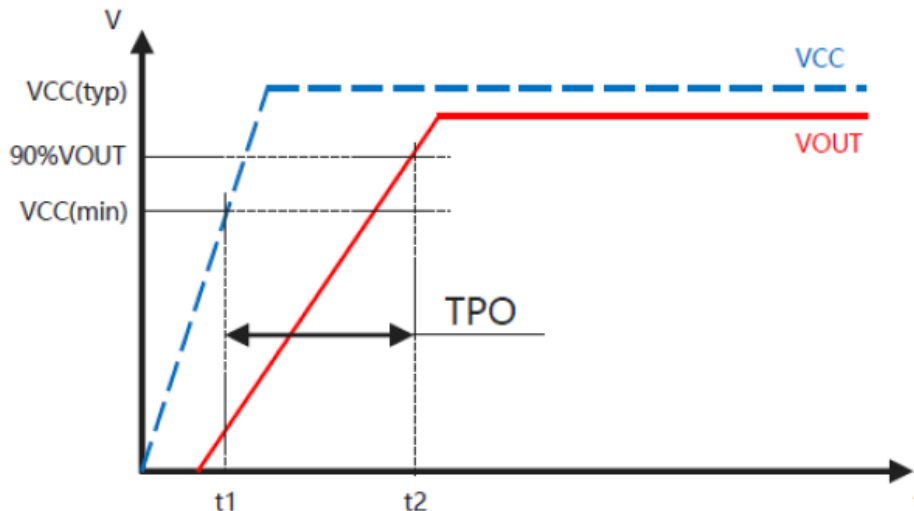

Temperature trimmed power-up time - TTC

After power-up, temperature trim time is required before a valid temperature compensation output is available.

Transmission delay - TPD

It is the time difference between when the current under test reaches 20% of its final value and when the output reaches 20% of its final value.

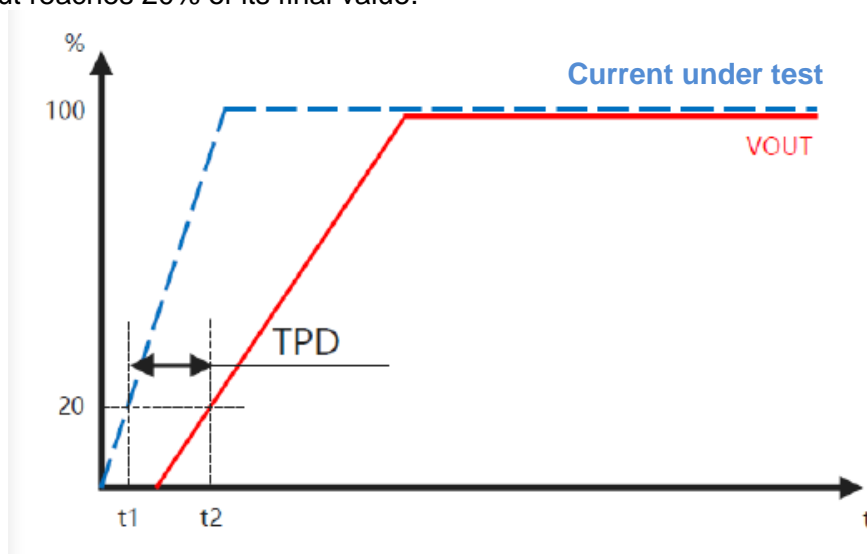

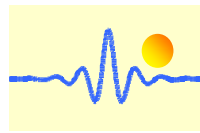

Rise time - TR

The time difference between the rising times of the IC output level from 10% to 90%, TR is negatively affected by eddy currents if a conductive plane ground is used.

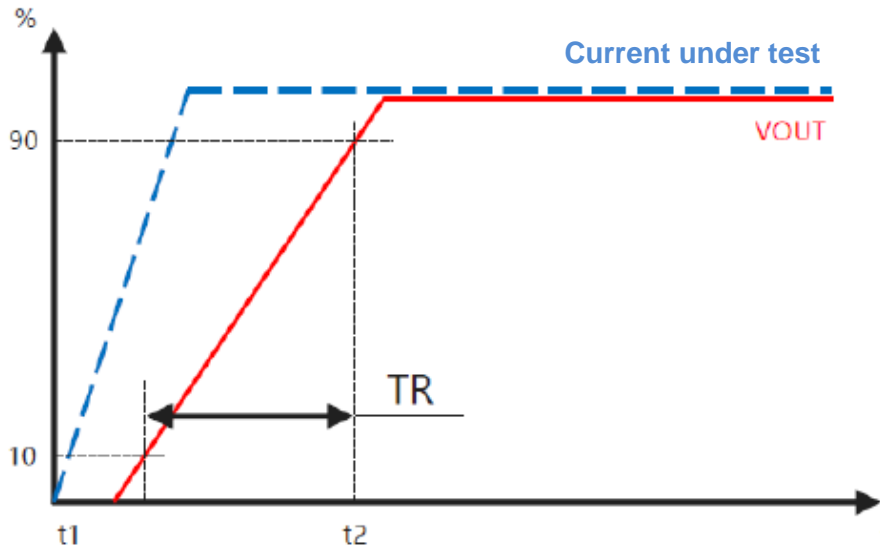

Response time – TRESP

It is the time difference when the current under test input to the IC reaches 80% of its final value and the corresponding output value the IC reaches 80%. The TRESP is negatively affected by eddy currents if a conductive plane ground is used.

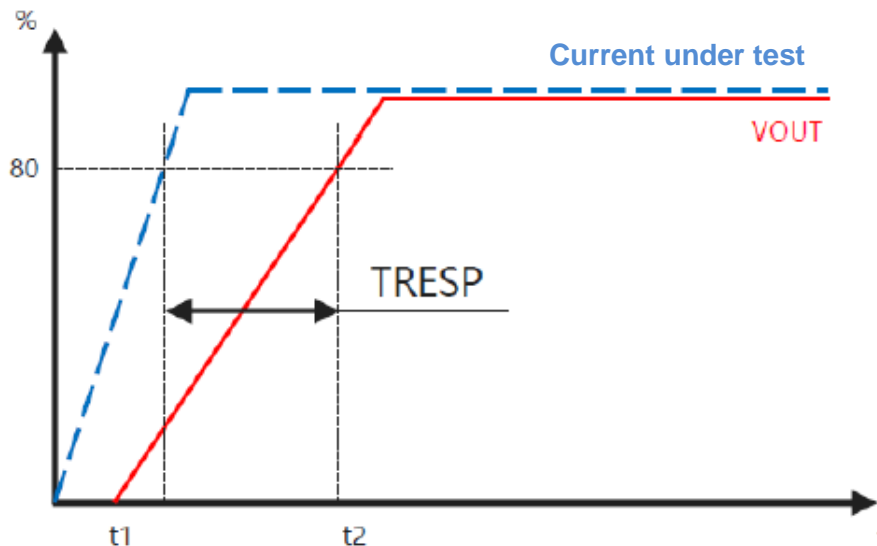

Static voltage output - VOQ

It is the output voltage of the IC at a zero current under test when both the supply voltage and the surrounding temperature are within the operating range.

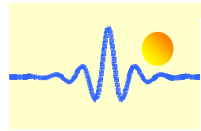

Static Voltage Output Error - VOE

It is the difference between the actual output voltage of the sensor and the ideal output voltage when the current under test is zero. At a fixed output voltage, the static voltage output error is the difference between the actual output voltage and the 2.5V voltage. In output mode proportional to the supply voltage, the static voltage output error is the difference between the actual output voltage and $VCC/2$.

Sensitivity - Sens

The sensitivity indicates the change in the sensor output in mV/A for every 1 Ampere change in the current under test.

It is defined by dividing the difference between the two output voltages of the sensor by the difference between positive and negative full-scale currents. The sensitivity of the sensor is calculated as follows:

$$SENS = (V_{out}(IP_{max}) - V_{out}(IN_{max})) / (IP_{max} - IN_{max})$$

Where IP_{max} and IN_{max} are positive full-scale current and negative full-scale current, respectively, $V_{out}(IP_{max})$ and $V_{out}(IN_{max})$ are the analog output voltages of the sensor for the positive full-scale current and negative full-scale current, respectively.

Error Range - ETOT

This error value represents the maximum error of the sensor in various environments. This value is equal to the absolute value of the measuring error in each temperature range over the full measuring range, divided by the maximum dynamic range of the sensor output. This can be expressed as follows:

$$ETOT(IP) = \text{Max}(V_{out} - V_{out_idea}) / (V_{out}(IP_{max}) - V_{oq})$$

Where $\text{Max}(V_{out} - V_{out_idea})$ represents the maximum error within the measuring range, and $(V_{out}(IP_{max}) - V_{oq})$ represents the maximum output dynamic range of the sensor.

Nonlinearity error – ELIN

Due to various factors affecting the operation of the sensor, the output voltage of the sensor is in practice not completely linear to the current under test. After least squares linear fitting, the maximum deviation between the sensor output voltage and the linear fitted line divided by the dynamic range of the sensor is defined as the linearity error of the sensor:

$$ELIN(IP) = \Delta V_{out} / (V_{out}(IP_{max}) - V_{oq})$$

Where, ΔV_{out} is the maximum absolute linear deviation in the measuring range of the sensor.

Noise (VNOISE)

Generated by thermal noise and scattered particle noise observed in Hall elements. The noise (mV) / sensitivity (mV/A) gives the minimum current that the device can resolve.

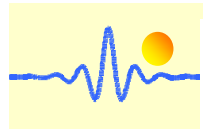

Copyright© 2022, ChenYang Technologies GmbH & Co. KG

(This material is published on October 25, 2022, last revision on October 25, 2022)

All rights reserved. No part of this data sheet may be reproduced, stored in a retrieval system or transmitted in any form or by any means, electronic, mechanical, photocopying, recording or otherwise, without the prior permission of the copyright holder.

Author and Contact Info:

Dr.-Ing. habil. Jigou Liu
ChenYang Technologies GmbH & Co. KG
Markt Schwabener Str. 8
85464 Finsing,
Germany
Tel. +49-8121-2574102,
Fax: +49-8121-2574101
Email: jigou.liu@chenyang-ism.com