

Hall Effect AC/DC Current Sensor CYHCS-K210

This Hall Effect current sensor is based on open loop principle and designed with a split core and a high galvanic isolation between primary conductor and secondary circuit. It can be used for measurement of AC/DC current etc. The output of the transducer reflects the real wave of the current carrying conductor.

Product Characteristics	Applications
<ul style="list-style-type: none"> • Excellent accuracy • Very good linearity • Light in weight • Less power consumption • Window structure • Electrically isolating the output of the transducer from the current carrying conductor • No insertion loss • Current overload capability 	<ul style="list-style-type: none"> • Photovoltaic equipment • Frequency conversion timing equipment • Various power supply • Uninterruptible power supplies (UPS) • Electric welding machines • Numerical controlled machine tools • Electrolyzing and electroplating equipment • Electric powered locomotive • Microcomputer monitoring • Electric power network monitoring

Electrical Data

Primary Nominal Current I_r (A)	Primary Current Measuring Range I_p (A)	Output Voltage (Analog)(V)	Part number
5000A	0 ~ ± 6000A	X=0: ±4V ±1.0% X=1: ±5V ±1.0% X=2: ±20mA ±1.0% X=8: ±10V ±1.0%	CYHCS-K210-5000A-X
6000A	0 ~ ± 7200A		CYHCS-K210-6000A-X
8000A	0 ~ ± 9600A		CYHCS-K210-8000A-X
10000A	0 ~ ± 12000A		CYHCS-K210-10000A-X
15000A	0 ~ ± 18000A		CYHCS-K210-15000A-X
20000A	0 ~ ± 22000A		CYHCS-K210-20000A-X
30000A	0 ~ ± 33000A		CYHCS-K210-30000A-X

This sensor can be customized for rated input current range from 3000A to 100000A.

Supply Voltage:	$V_{cc} = \pm 12V \sim \pm 15VDC \pm 5\%$
Current Consumption	$I_c < 50mA$
Isolation Voltage	6kV, 50/60Hz, 1min
Output Voltage at I_r , $T_A = 25^\circ C$:	$V_{out} = 4VDC$
Output Impedance:	$R_{out} < 150\Omega$
Load Resistor:	$R_L > 10k\Omega$
Accuracy at I_r , $T_A = 25^\circ C$ (without offset),	$E < 1.0\%$
Linearity from 0 to I_r , $T_A = 25^\circ C$,	$E_L < 1.0\% FS$
Linear Measuring range,	1.2 times of measuring range
Overload capability,	3 times of measuring range
Electric Offset Voltage, $T_A = 25^\circ C$,	$V_{oe} < \pm 30mV$
Magnetic Offset Voltage ($I_r \rightarrow 0$)	$V_{om} < \pm 40mV$
Thermal Drift of Offset Voltage,	$V_{ot} < \pm 1.0mV/^\circ C$
Thermal Drift ($-10^\circ C$ to $50^\circ C$),	T.C. $< \pm 0.1\% /^\circ C$
Response Time at 90% of I_p ($f = 1k Hz$)	$t_r < 10\mu s$
Frequency Bandwidth (-3dB),	$f_b = DC-3 kHz$

General Data

Ambient Operating Temperature,	$T_A = -25^\circ C \sim +85^\circ C$
Ambient Storage Temperature,	$T_S = -40^\circ C \sim +100^\circ C$
Unit Weight,	6200g

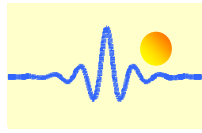

PIN Definition and Dimensions

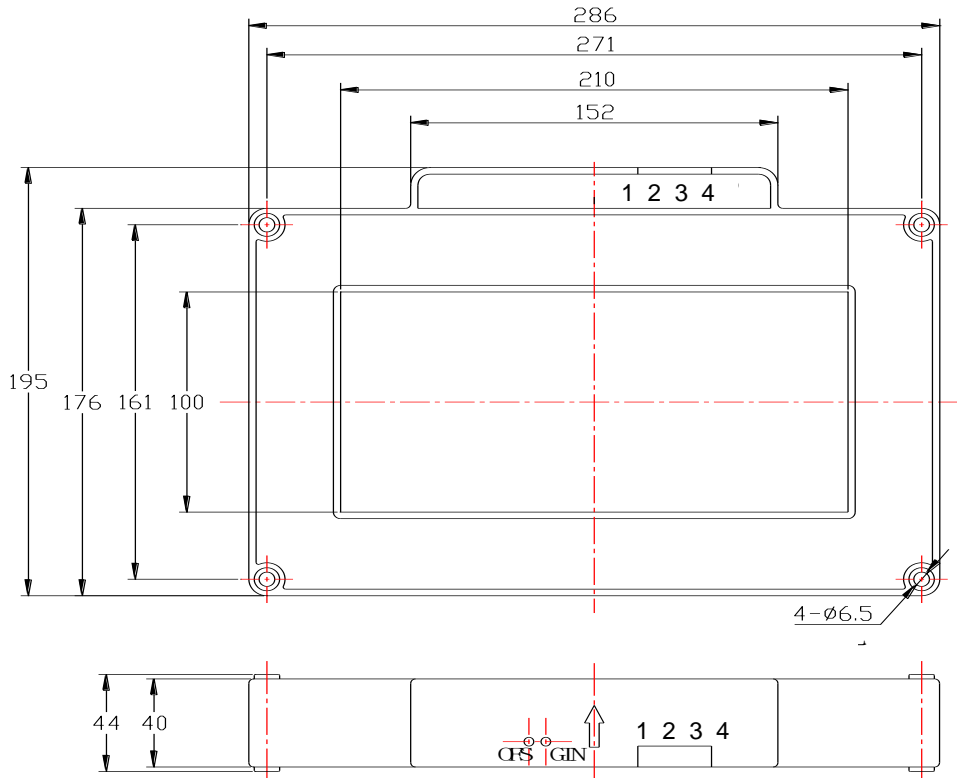

Pin arrangement:

- 1(V+): Vcc
- 2(V-): -Vcc
- 3(OUT): OUTPUT
- 4(GND): 0V (GND)

OFS: Offset Adjustment

GIN: Gain Adjustment

Sensor Connection – Voltage Output

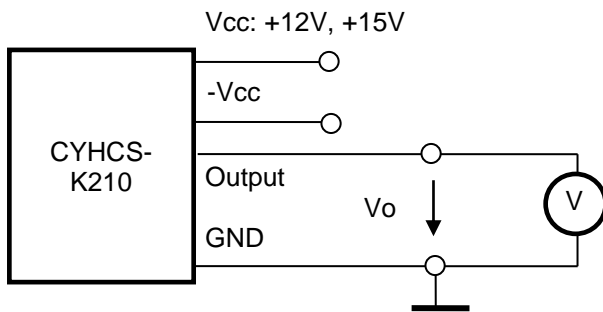

Sensor Connection – Current Output

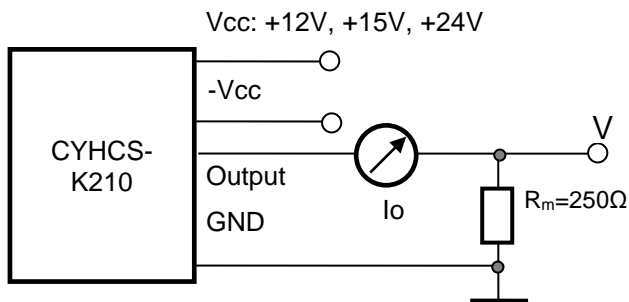

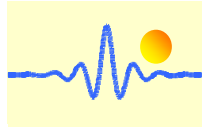

Notes:

1. Connect the terminals of power source, output respectively and correctly, never make wrong connection.
2. Two potentiometers can be adjusted, only, if necessary, by turning slowly to the required accuracy with a small screwdriver.
3. The best accuracy can be achieved when the window is fully filled with busbar (current carrying conductor).
4. The in-phase output can be obtained when the direction of current of current carrying conductor is the same as the direction of arrow marked on the transducer