

Hall Effect AC Current Sensor CYHCS-HBV

This Hall Effect current sensor is based on open loop principle and designed with a high galvanic isolation between primary conductor and secondary circuit. It can be used for measurement of AC current, pulse currents etc. The output of the transducer reflects the rectified average value of the current in the carrying conductor.

Product Characteristics	Applications
<ul style="list-style-type: none"> • Excellent accuracy • Very good linearity • easy mounting • Less power consumption • Window structure • Electrically isolating the output of the transducer from the current carrying conductor • No insertion loss • Current overload capability 	<ul style="list-style-type: none"> • Photovoltaic equipment • Frequency conversion timing equipment • Various power supply • Uninterruptible power supplies (UPS) • Electric welding machines • Transformer substation • Numerical controlled machine tools • Electric powered locomotive • Microcomputer monitoring • Electric power network monitoring

Electrical Data

Primary Nominal Current I_r (A), rms	Measuring Range (A)	DC Output Voltage (V)	Window Size (mm)	Part number
2000	0~±2000	x=0: 0-4V ±1.0% x=3: 0-5V ±1.0% x=8: 0-10V ±1.0%	140 x 50	CYHCS-HBV-2000A-xn
3000	0~±3000			CYHCS-HBV-3000A-xn
4000	0~±4000			CYHCS-HBV-4000A-xn
5000	0~±5000			CYHCS-HBV-5000A-xn
6000	0~±6000			CYHCS-HBV-6000A-xn
8000	0~±8000			CYHCS-HBV-8000A-xn
9000	0~±9000			CYHCS-HBV-9000A-xn
10000	0~±10000			CYHCS-HBV-10000A-xn

(n=2, V_{cc} = +12VDC; n=3, V_{cc} =+15VDC; n=4, V_{cc} =+24VDC)

Supply Voltage	V_{cc} = +12V, +15V, +24VDC ± 5%
Output Voltage at I_r , $T_A=25^\circ\text{C}$:	V_{out} =0- 4V, 0-5V, 0-10VDC
Current Consumption	I_c < 25mA
Galvanic isolation, 50/60Hz, 1min:	3kV rms
Output Impedance:	R_{out} < 150Ω
Load resistance:	10kΩ

Accuracy and Dynamic performance data

Accuracy at I_r , $T_A=25^\circ\text{C}$,	X <±1.0% FS
Linearity from 0 to I_r , $T_A=25^\circ\text{C}$,	E_L <±0.5% FS
Electric Offset Voltage, $T_A=25^\circ\text{C}$,	V_{oe} <50mV
Magnetic Offset Voltage ($I_r \rightarrow 0$)	V_{om} <±20mV
Thermal Drift of Offset Voltage,	V_{ot} <±1.0mV/°C
Response Time at 90% of I_P ($f=1\text{k Hz}$)	t_r < 200ms
Frequency Bandwidth (-3dB),	f_b = 20Hz - 20 kHz
Case Material:	PBT

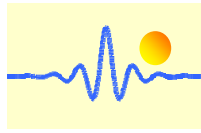

General Data

Ambient Operating Temperature,
Ambient Storage Temperature,

$T_A = -25^{\circ}\text{C} \sim +85^{\circ}\text{C}$
 $T_S = -40^{\circ}\text{C} \sim +100^{\circ}\text{C}$

Dimensions

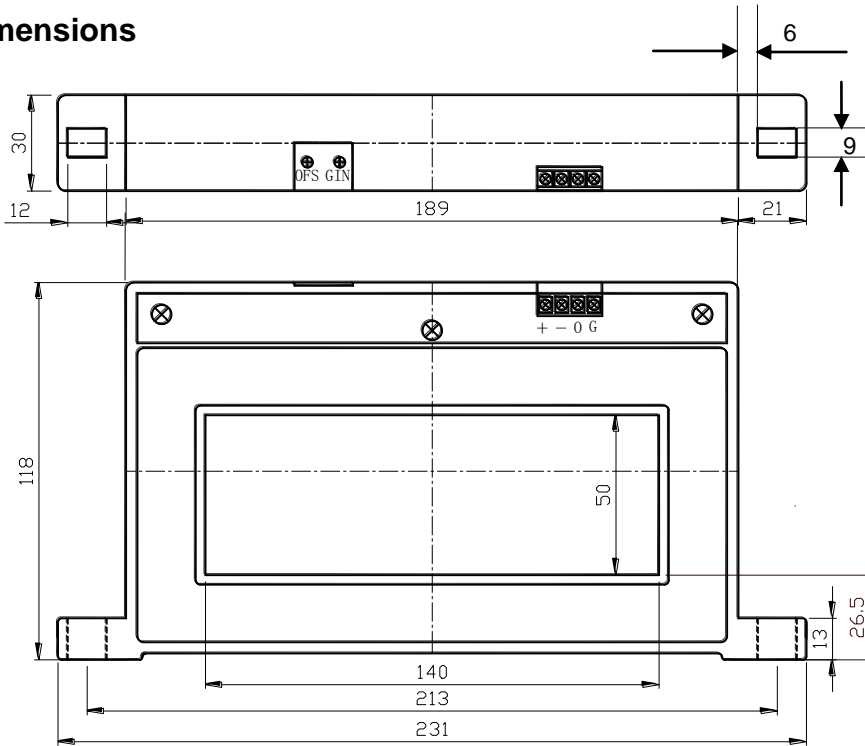

Pin Arrangement

+: Vcc
-: Ground (GND)
O: Output
G: Ground (GND)

GIN: gain adjustment
OFS: offset adjustment

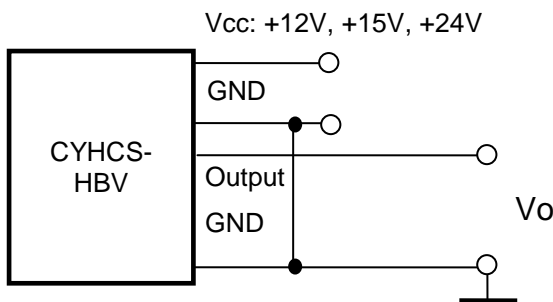

Notes:

1. Connect the terminals of power source, output respectively and correctly, never make wrong connection.
2. Two potentiometers can be adjusted, only if necessary, by turning slowly to the required accuracy with a small screwdriver.
3. The best accuracy can be achieved when the window is fully filled with bus-bar (current carrying conductor).
4. The in-phase output can be obtained when the direction of current of current carrying conductor is the same as the direction of arrow marked on the transducer