

Hall Effect AC Current Sensor CYHCS-FAV

This Hall Effect current sensor is based on open loop principle and designed with a high galvanic isolation between primary conductor and secondary circuit. It can be used for measurement of AC current, pulse currents etc. The output of the transducer reflects the rectified average value of the current in the carrying conductor.

Product Characteristics	Applications
<ul style="list-style-type: none"> • Excellent accuracy • Very good linearity • Using split cores and easy mounting • Less power consumption • Window structure • Electrically isolating the output of the transducer from the current carrying conductor • No insertion loss • Current overload capability 	<ul style="list-style-type: none"> • Photovoltaic equipment • Various power supply • Uninterruptible power supplies (UPS) • Electric welding machines • Transformer substation • Numerical controlled machine tools • Electric powered locomotive • Microcomputer monitoring • Electric power network monitoring

Electrical Data

Primary Nominal Current I_r (A), rms	Measuring Range (A)	DC Output Voltage (V)	Window size (mm)	Part number
300	0~±300	x=0: 0-4V ±1.0% x=3: 0-5V ±1.0% x=8: 0-10V ±1.0%	51x13	CYHCS-FAV-300A-xn
400	0~±400			CYHCS-FAV-400A-xn
500	0~±500			CYHCS-FAV-500A-xn
600	0~±600			CYHCS-FAV-600A-xn
800	0~±800			CYHCS-FAV-800A-xn
1000	0~±1000			CYHCS-FAV-1000A-xn
1500	0~±1500			CYHCS-FAV-1500A-xn
2000	0~±2000			CYHCS-FAV-2000A-xn

(n=2, $V_{cc}=+12VDC$; n=3, $V_{cc}=+15VDC$; n=4, $V_{cc}=+24VDC$; n=5, $V_{cc}=\pm 12VDC$, n=6, $V_{cc}=\pm 15VDC$)

Supply Voltage	$V_{cc}= +12V, +15V, +24VDC \pm 5\%, \dots$
Output Voltage at $I_r, T_A=25^\circ C$:	$V_{out}=0- 4V, 0-5V, 0-10VDC$
Current Consumption	$I_c < 25mA$
Galvanic isolation, 50/60Hz, 1min:	3kV rms
Output Impedance:	$R_{out} < 150\Omega$
Load resistance:	10k Ω

Accuracy and Dynamic performance data

Accuracy at $I_r, T_A=25^\circ C$,	$X < \pm 1.0\% FS$
Linearity from 0 to $I_r, T_A=25^\circ C$,	$E_L < \pm 0.5\% FS$
Electric Offset Voltage, $T_A=25^\circ C$,	$V_{oe} < 50mV$
Magnetic Offset Voltage ($I_r \rightarrow 0$)	$V_{om} < \pm 20mV$
Thermal Drift of Offset Voltage,	$V_{ot} < \pm 1.0mV/^\circ C$
Response Time at 90% of I_P ($f=1k Hz$)	$t_r < 200ms$
Frequency Bandwidth (-3dB),	$f_b = 20Hz - 20 kHz$
Case Material:	PBT heat resistant $125^\circ C$, flame retardant

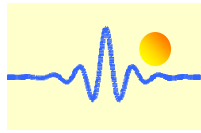

General Data

Ambient Operating Temperature,
Ambient Storage Temperature,
Unit weight:

$T_A = -25^{\circ}\text{C} \sim +85^{\circ}\text{C}$
 $T_S = -40^{\circ}\text{C} \sim +100^{\circ}\text{C}$
300g/unit

Dimensions

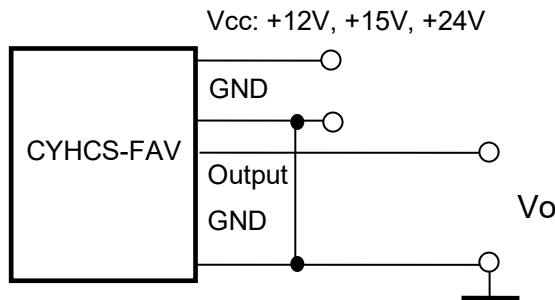
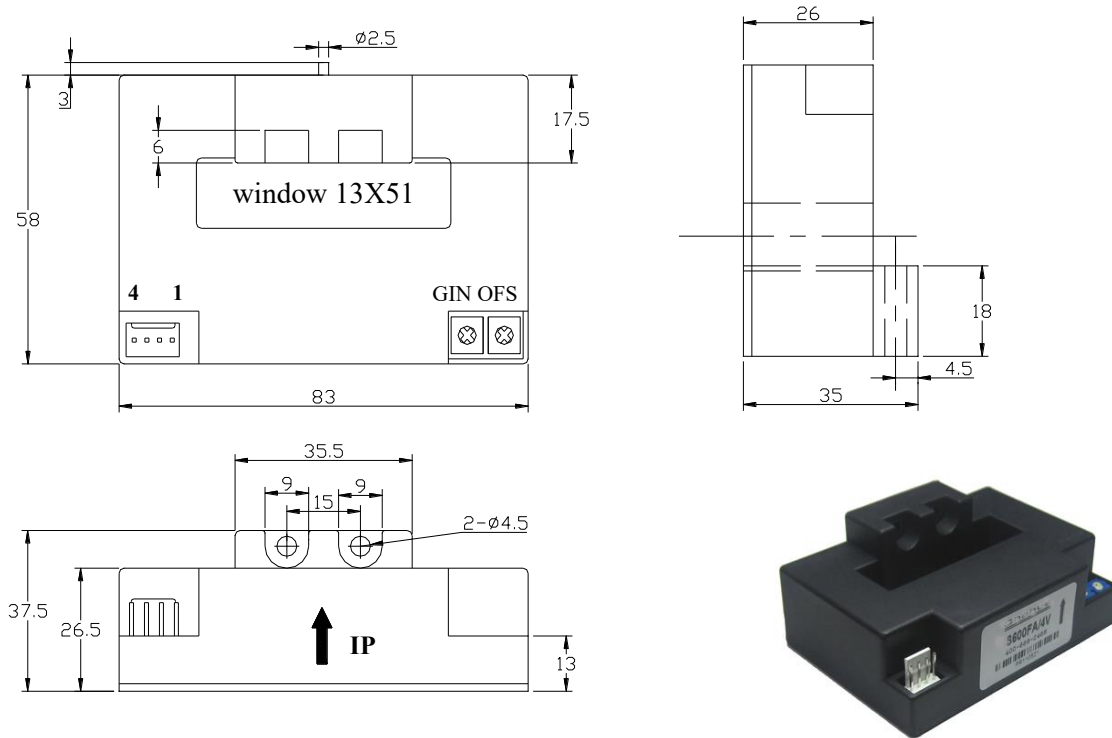

Pin Arrangement

1: Vcc
2: Ground
3: Output
4: Ground

GIN: gain adjustment
OFS: offset adjustment

Notes:

1. Connect the terminals of power source, output respectively and correctly, never make wrong connection.
2. Two potentiometers can be adjusted, only if necessary, by turning slowly to the required accuracy with a small screwdriver.
3. The best accuracy can be achieved when the window is fully filled with bus-bar (current carrying conductor).
4. The in-phase output can be obtained when the direction of current of current carrying conductor is the same as the direction of arrow marked on the transducer