

Closed Loop Hall AC/DC Current Sensor CYHCS-ES5

This Hall Effect current sensor is based on the closed loop compensating principle and designed with a high galvanic isolation between primary conductor and secondary circuit. It can be used for measurement of DC and AC current, pulse currents etc. The output of the transducer reflects the real wave of the current carrying conductor.

Product Characteristics	Applications
<ul style="list-style-type: none"> • Excellent accuracy • Very good linearity • Small size and encapsulated • Less power consumption • Current overload capability 	<ul style="list-style-type: none"> • Photovoltaic equipment • General Purpose Inverters • AC/DC Variable Speed Drivers • Battery Supplied Applications • Uninterruptible Power Supplies • Switched Mode Power Supplies

Electrical Data/Input

Part number	Primary Rated Current I_r (A)	Measuring Range I_o (A)	Turns ratio	Internal measuring resistor (Ω)
CYHCS-ES5-10A	10	± 20	1:1200	30 \pm 0.1%
CYHCS-ES5-25A	25	± 50	1:1200	12 \pm 0.1%
CYHCS-ES5-50A	50	± 100	1:1200	6 \pm 0.1%
CYHCS-ES5-75A	75	± 150	1:1500	5 \pm 0.1%
CYHCS-ES5-100A	100	± 200	1:2000	5 \pm 0.1%

Rated Output Voltage:	+2.5V \pm 1.0V \pm 0.2%FS
Supply Voltage	+5V \pm 2%,
Reference voltage R:	+2.5VDC \pm 0.4% FS
Electric Offset Voltage	+2.5VDC \pm 0.4%FS
Current Consumption (at $V_{out}=0V$)	<20mA
Isolation voltage (50/60Hz, 1min)	3.0kV
Accuracy:	0.5% FS
Linearity:	<0.1% FS
Thermal Drift of Offset Voltage (-40°C~+105°C),	\pm 0.05mV/°C
Thermal Drift of Output Voltage (-40°C~+105°C),	\pm 0.05mV/°C
Response Time:	< 0.50 μ s
Di/dt following accuracy:	100A/ μ s
Frequency Bandwidth (-1dB):	DC ~ 200 kHz

General Data

Ambient Operating Temperature:	-40°C ~ +105°C
Ambient Storage Temperature:	-40°C~ +125°C

Standard

UL94-V0, EN60947-1:2004, IEC60950-1:2001, EN50178:1998, SJ20790-2000

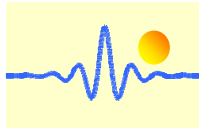

Relation between Input Current and Output Voltage

Take the sensor CYHCS-ES5-25A as sample, the relation between the input current and output voltage is shown in the table 1, Fig.1 and Fig. 2

Table 1. Relation between the input current and output voltage

Input current (A)	-55	-40	-25	-15	0	15	25	40	55
Output voltage (V)	0.3	0.9	1.5	1.9	2.5	3.1	3.5	4.1	4.7

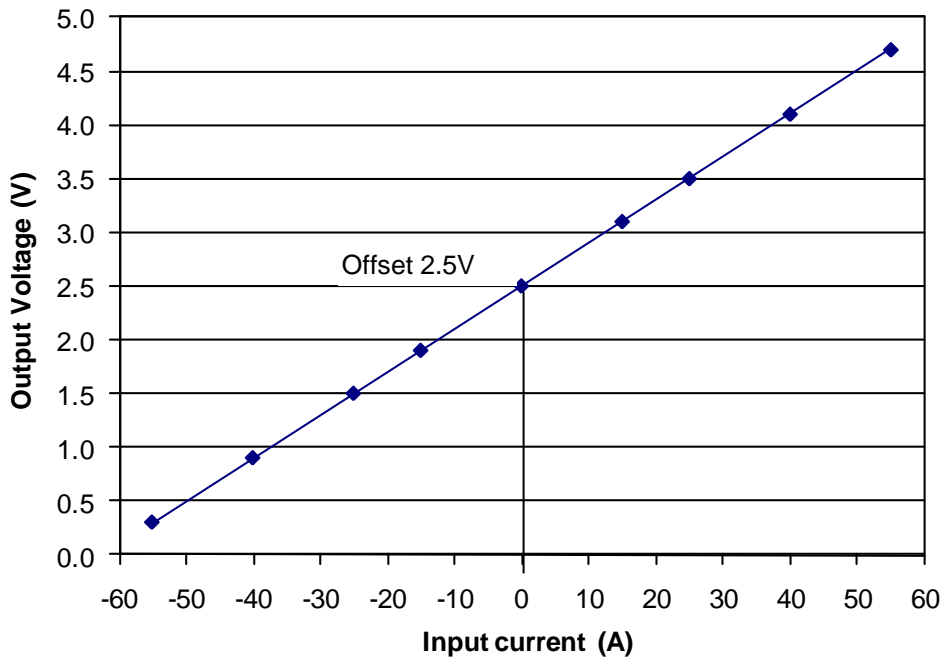

Fig. 1 Relation between the input current (DC) and output voltage (DC)

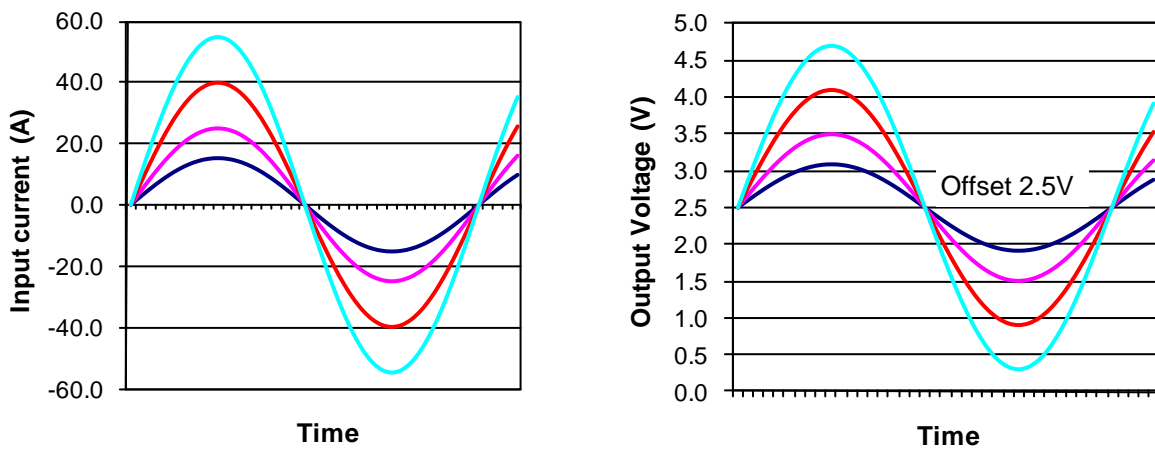

Fig. 2 Relation between the input current (AC) and output voltage (AC)

Dimensions (mm)

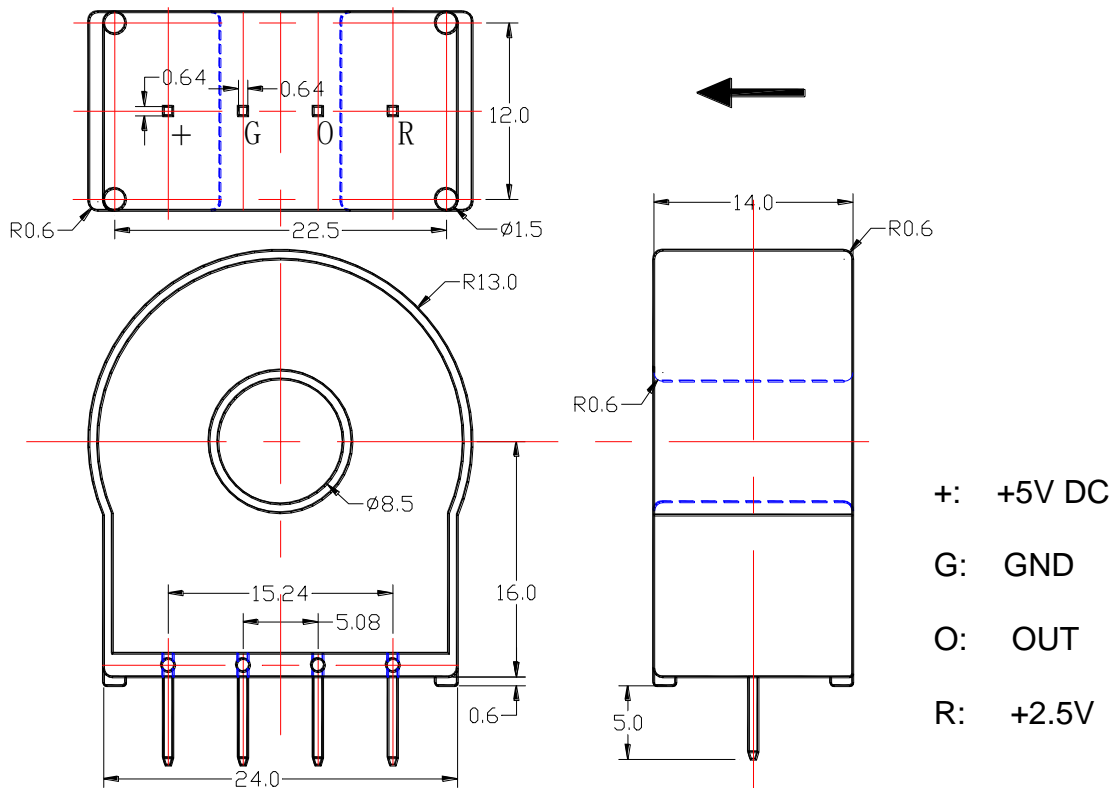

Fig. 3 Dimensions of CYHCS-ES5

Connection

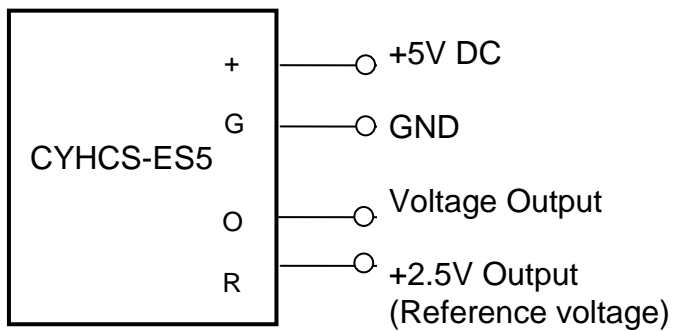

Fig. 4 Connection of CYHCS-ES5

Operating instructions

1. Connect the pins of power source, output respectively and correctly, never make wrong connection for DC current.
2. Temperature of the primary conductor should not exceed 120 °C.