

Split Core Hall Effect AC/DC Current Sensor CYHCS-EKT

This Hall Effect current sensor is based on open loop principle and designed with a split core and a high galvanic isolation between primary conductor and secondary circuit. It can be used for measurement of AC/DC current etc. The output of the transducer reflects the real wave of the current carrying conductor. It can be mounted on the primary cable directly.

Product Characteristics	Applications
<ul style="list-style-type: none"> • Excellent accuracy • Very good linearity • Light in weight • Less power consumption • Window structure, easily mounting • Electrically isolating the output of the transducer from the current carrying conductor • No insertion loss • Current overload capability 	<ul style="list-style-type: none"> • Photovoltaic equipment • Frequency conversion timing equipments • Various power supply • Uninterruptible power supplies (UPS) • Electric welding machines • Numerical controlled machine tools • Electrolyzing and electroplating equipments • Electric powered locomotive • Microcomputer monitoring • Electric power network monitoring

Electrical Data

Primary Nominal Current I_r (A)	Primary Current Measuring Range I_p (A)	Output Voltage (V)	Part number
10A	0 ~ ± 20A	2.5V±1V ±1.0%	CYHCS-EKT-10A-n
20A	0 ~ ± 40A		CYHCS-EKT-20A-n
25A	0 ~ ± 50A		CYHCS-EKT-25A-n
50A	0 ~ ± 80A		CYHCS-EKT-50A-n

n=2 for power supply: +5VDC;

n=3 for power supply: +12VDC

Supply Voltage:

Current Consumption

Isolation Voltage

$V_{cc}=+12VDC \pm 5\%$ or $+5VDC \pm 5\%$

$I_c < 10mA$

2,5kV, 50/60Hz, 1min

Output Voltage at I_r , $T_A=25^\circ C$:

Reverse Voltage:

Output Impedance:

Load Resistor:

$V_{out}=2.5V \pm 1V \pm 1.0\%$

$V_{rev}=18V > 1hr$

$R_{out} < 150\Omega$

$R_L > 4.7k\Omega$

Accuracy at I_r , $T_A=25^\circ C$ (without offset),

Linearity from 0 to I_r , $T_A=25^\circ C$,

Electric Offset Voltage, $T_A=25^\circ C$,

Magnetic Offset Voltage ($I_r \rightarrow 0$)

Thermal Drift of Offset Voltage ($I_p=0$, $-25^\circ C \sim +85^\circ C$),

Thermal Drift ($-10^\circ C$ to $50^\circ C$),

Response Time at 90% of I_p ($f=1k$ Hz)

Frequency Bandwidth (-3dB),

$X < 1.0\%$

$E_L < 0.5\% FS$

$V_{oe} = 2.5V \pm 25mV$

$V_{om} < \pm 20mV$

$V_{ot} < \pm 0.25mV/^\circ C$

T.C. $< \pm 0.1\% / ^\circ C$

$t_r < 7\mu s$

$f_b = DC-2.2$ kHz

General Data

Ambient Operating Temperature,

Ambient Storage Temperature,

Unit weight:

$T_A = -40^\circ C \sim +85^\circ C$

$T_S = -55^\circ C \sim +100^\circ C$

21g / unit

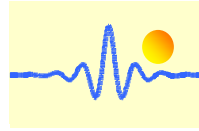

PIN Definition and Dimensions

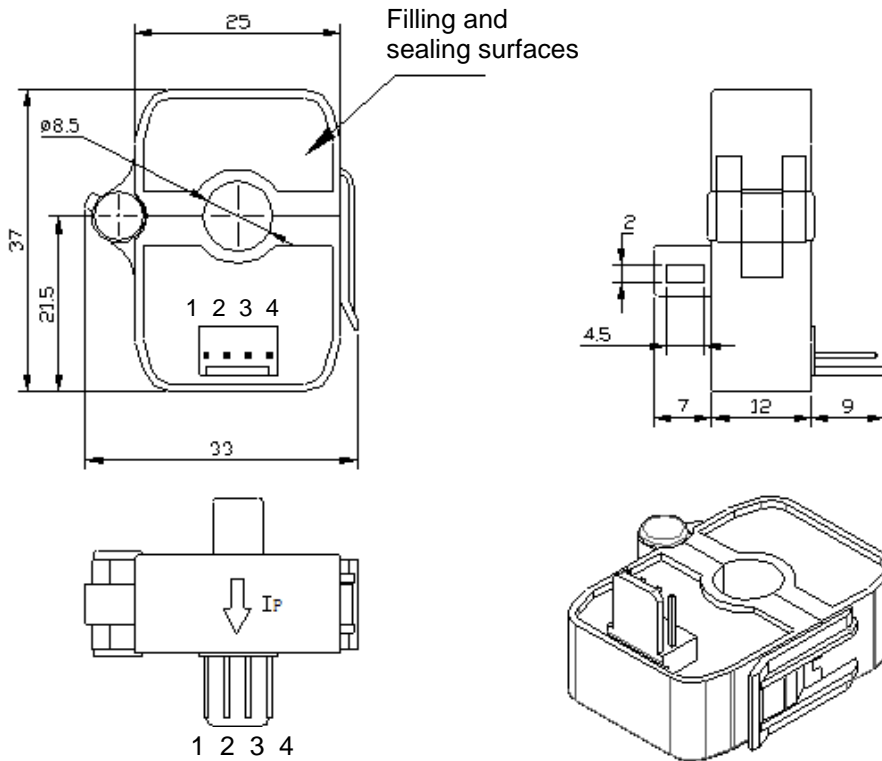

1) Pin arrangement:

- 1 (V+): +12V
- 2 (NC): NC
- 3 (OUT): OUTPUT
- 4 (GND): 0V (GND)

2) Pin arrangement:

- 1 (NC): NC
- 2 (V+): +5VDC
- 3 (OUT): OUTPUT
- 4 (GND): 0V (GND)

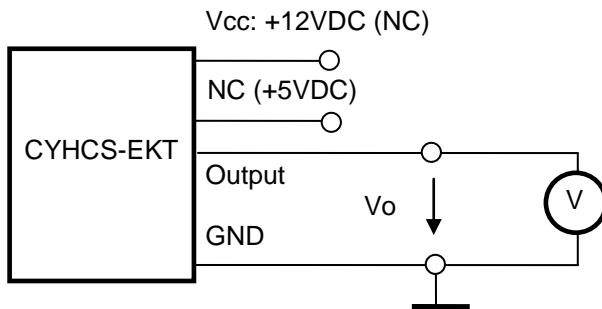

Notes:

1. Connect the terminals of power source, output respectively and correctly, never make wrong connection.
2. Two potentiometers can be adjusted, only if necessary, by turning slowly to the required accuracy with a small screwdriver.
3. The best accuracy can be achieved when the window is fully filled with bus-bar (current carrying conductor).
4. The in-phase output can be obtained when the direction of current of current carrying conductor is the same as the direction of arrow marked on the transducer