

Split Core Hall Effect AC Current Sensor CYHCS-EKOV

This Hall Effect current sensor is based on open loop principle and designed with a high galvanic isolation between primary conductor and secondary circuit. It can be used for measurement of AC current, pulse currents etc. The output of the transducer reflects the rectified average value of the current in the carrying conductor.

Product Characteristics	Applications
<ul style="list-style-type: none"> • Excellent accuracy • Very good linearity • Less power consumption • Split core window structure • Electrically isolating the output of the transducer from the current carrying conductor • No insertion loss • Current overload capability 	<ul style="list-style-type: none"> • Photovoltaic equipment • Frequency conversion timing equipment • Various power supply • Uninterruptible power supplies (UPS) • Electric welding machines • Electrolyzing and electroplating equipment • Electric powered locomotive • Electric power network monitoring

Technical Data

Primary Nominal Current I_r (A), RMS	Primary Current Measuring Range I_p (A)	DC Output Voltage (V)	Part number
500A	0 ~ ± 500A	x=0: 0-4V ±1.0%	CYHCS-EKOV-500A-xn
1000A	0 ~ ± 1000A	x=3: 0-5V ±1.0%	CYHCS-EKOV-1000A-xn
2000A	0 ~ ± 2000A	x=8: 0-10V ±1.0%	CYHCS-EKOV-2000A-xn
5000A	0 ~ ± 5000A	(For 0-10V output the power supply must be 15VDC or 24VDC)	CYHCS-EKOV-5000A-xn
8000A	0 ~ ± 8000A		CYHCS-EKOV-8000A-xn
10000A	0 ~ ± 10000A		CYHCS-EKOV-10000A-xn
12000A	0 ~ ± 12000A	x=S: Special output	CYHCS-EKOV-12000A-xn
15000A	0 ~ ± 15000A		CYHCS-EKOV-15000A-xn

(n=2, V_{cc} = +12VDC; n=3, V_{cc} =+15VDC; n=4, V_{cc} =+24VDC; n=5, V_{cc} =±12VDC; n=6, V_{cc} =±15VDC; n=7, V_{cc} =±24VDC)

Supply Voltage:	V_{cc} =+12V, +15V, +24V, ±12V, ±15VDC ± 5%
Current Consumption (V_c =±15VDC):	I_c < 50mA
Isolation Voltage	6kV, 50/60Hz, 1min
Load Resistor:	R_L > 10kΩ
Accuracy at I_r , T_A =25°C (without offset),	X <1.0%
Linearity from 0 to I_r , T_A =25°C,	E_L <1.0% FS
Linear Measuring range,	1.2 times of measuring range
Overload capability,	3 times of measuring range
Electric Offset Voltage, T_A =25°C,	V_{oe} <±25mV
Magnetic Offset Voltage (I_r →0)	V_{om} <±25mV
Thermal Drift of Offset Voltage,	V_{ot} <±1.0mV/°C
Response Time at 90% of I_p (f =1k Hz)	t_r <200ms
Frequency Bandwidth (-3dB),	f_b = 20Hz - 3kHz
Ambient Operating Temperature:	T_A =-25°C ~ +85°C
Ambient Storage Temperature:	T_S =-40°C ~ +100°C
Unit Weight:	1165g/pc
Standard:	Q/320115QHKJ01-2016

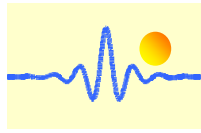

PIN Definition and Dimensions

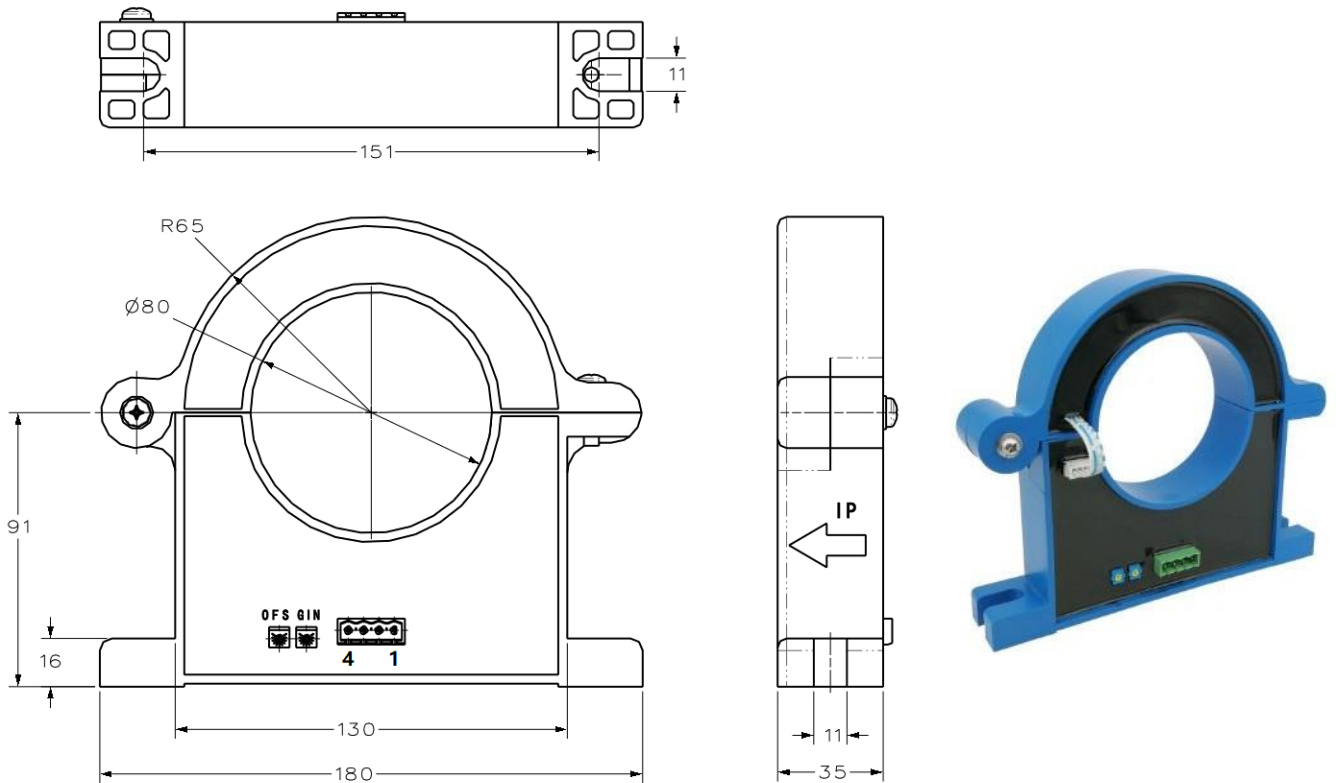

OFS: Offset Adjustment

GIN: Gain Adjustment

Pin arrangement of connector:

1: Vcc 2: -Vcc or GND
3: OUTPUT 4: 0V (GND)

Cable connection:

Red: Vcc
Blue: -Vcc or GND
Yellow: OUTPUT
Black: 0V (GND)

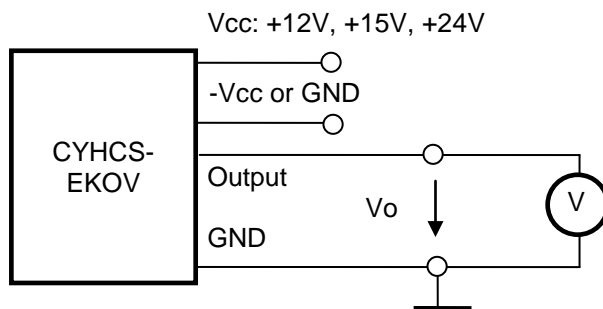

Notes:

1. Connect the terminals of power source, output respectively and correctly, never make wrong connection.
2. Two potentiometers can be adjusted, only if necessary, but slowly to the required accuracy with a small screwdriver.
3. The best accuracy can be achieved when the window is fully filled with current carrying conductor.
4. The in-phase output can be obtained when the current direction of current carrying conductor is the same as the direction of arrow marked on the transducer