

Split Core Hall Effect AC/DC Current Sensor CYHCS-EKOS

This Hall Effect current sensor is based on open loop principle and designed with a split core and a high galvanic isolation between primary conductor and secondary circuit. It can be used for measurement of AC/DC current etc. The output of the transducer reflects the real wave of the current carrying conductor.

Product Characteristics	Applications
<ul style="list-style-type: none"> • Excellent accuracy • Very good linearity • Less power consumption • Split core window structure • Electrically isolating the output of the transducer from the current carrying conductor • No insertion loss • Current overload capability 	<ul style="list-style-type: none"> • Photovoltaic equipment • Frequency conversion timing equipment • Various power supply • Uninterruptible power supplies (UPS) • Electric welding machines • Electrolyzing and electroplating equipment • Electric powered locomotive • Electric power network monitoring

Electrical Data

Primary Nominal Current I_r (A)	Measuring Range I_p (A)	Output Voltage (Analog)(V)	Window Size (mm)	Part number
500A	0 ~ ± 675A	2.5VDC±1.5V	Ø80	CYHCS-EKOS-500A
1000A	0 ~ ± 1350A			CYHCS-EKOS-1000A
2000A	0 ~ ± 2700A			CYHCS-EKOS-2000A
5000A	0 ~ ± 6000A			CYHCS-EKOS-5000A
8000A	0 ~ ± 10000A			CYHCS-EKOS-8000A
10000A	0 ~ ± 12000A			CYHCS-EKOS-10000A
12000A	0 ~ ± 15000A			CYHCS-EKOS-12000A
15000A	0 ~ ± 18000A			CYHCS-EKOS-15000A
20000A	0 ~ ± 24000A			CYHCS-EKOS-20000A

Supply Voltage:	$V_{cc}=+5VDC \pm 5\%$
Current Consumption ($V_c=\pm 15VDC$):	$I_c < 50mA$
Isolation Voltage:	6kV, 50/60Hz, 1min
Output Impedance:	$R_{out} < 150\Omega$
Load Resistor:	$R_L > 10k\Omega$
Accuracy at I_r , $T_A=25^\circ C$ (without offset):	$E < 1.0\% FS$
Linearity from 0 to I_r , $T_A=25^\circ C$:	$E_L < 1.0\% FS$
Linear Measuring range:	1.2 ~ 1.35 times of measuring range
Overload capability:	3 times of measuring range
Electric Offset Voltage, $T_A=25^\circ C$:	$V_{oe} = 2.5VDC \pm 1.0\%$
Magnetic Offset Voltage ($I_r \rightarrow 0$):	$V_{om} < \pm 25mV$
Thermal Drift of Offset Voltage ($I_p=0$, $T_A=-25^\circ C \sim 85^\circ C$):	$V_{ot} < \pm 1.0mV/^\circ C$
Response Time at 90% of I_p ($f=1k Hz$):	$t_r < 10\mu s$
Frequency Bandwidth (-3dB):	$f_b = DC - 6kHz$

General Data

Ambient Operating Temperature:	$T_A = -25^\circ C \sim +85^\circ C$
Ambient Storage Temperature:	$T_S = -40^\circ C \sim +100^\circ C$
Unit Weight:	1165g/pc
Standard:	Q/320115QHKJ01-2016

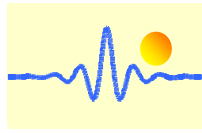

Relation between Input Current and Output Voltage

Take the sensor CYHCS-EKLS-10000A as sample, the relation between the input current and output voltage is shown in the table 1, Fig.1 and Fig. 2

Table 1. Relation between the input current and output voltage

Input current (A)	-12k	-10k	-7.5k	-5k	-2.5k	0	2.5k	5k	7.5k	10k	12k
Output voltage (V)	0.7	1.0	1.375	1.75	2.125	2.5	2.875	3.25	3.625	4.0	4.3

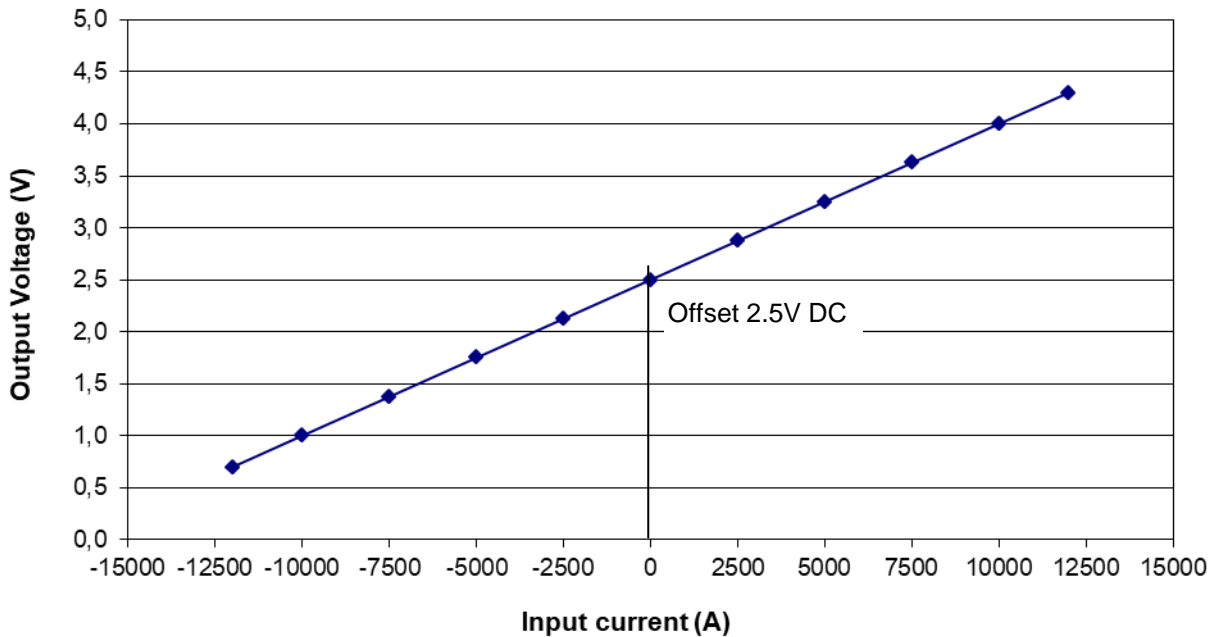

Fig. 1 Relation between the input current (DC) and output voltage (DC)

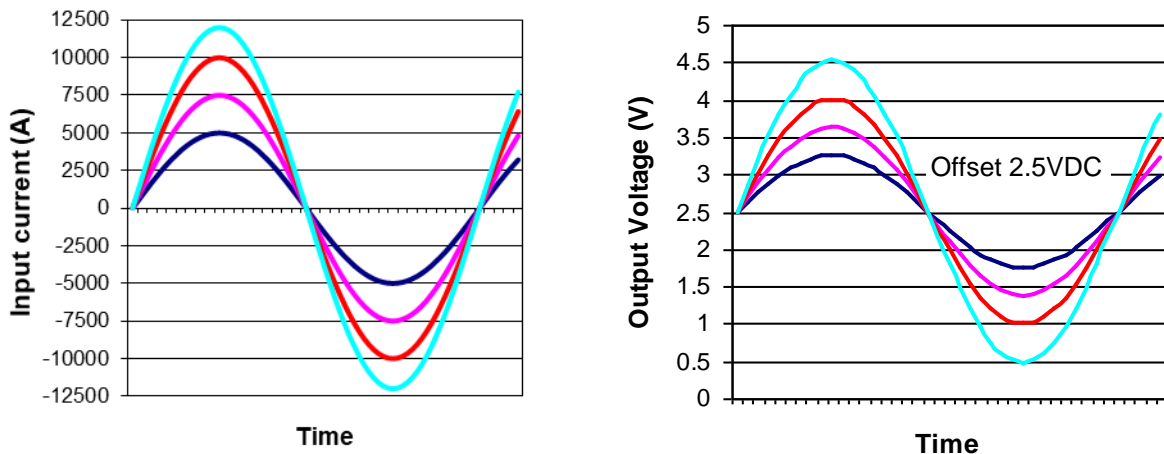
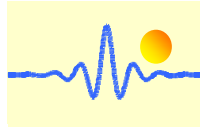
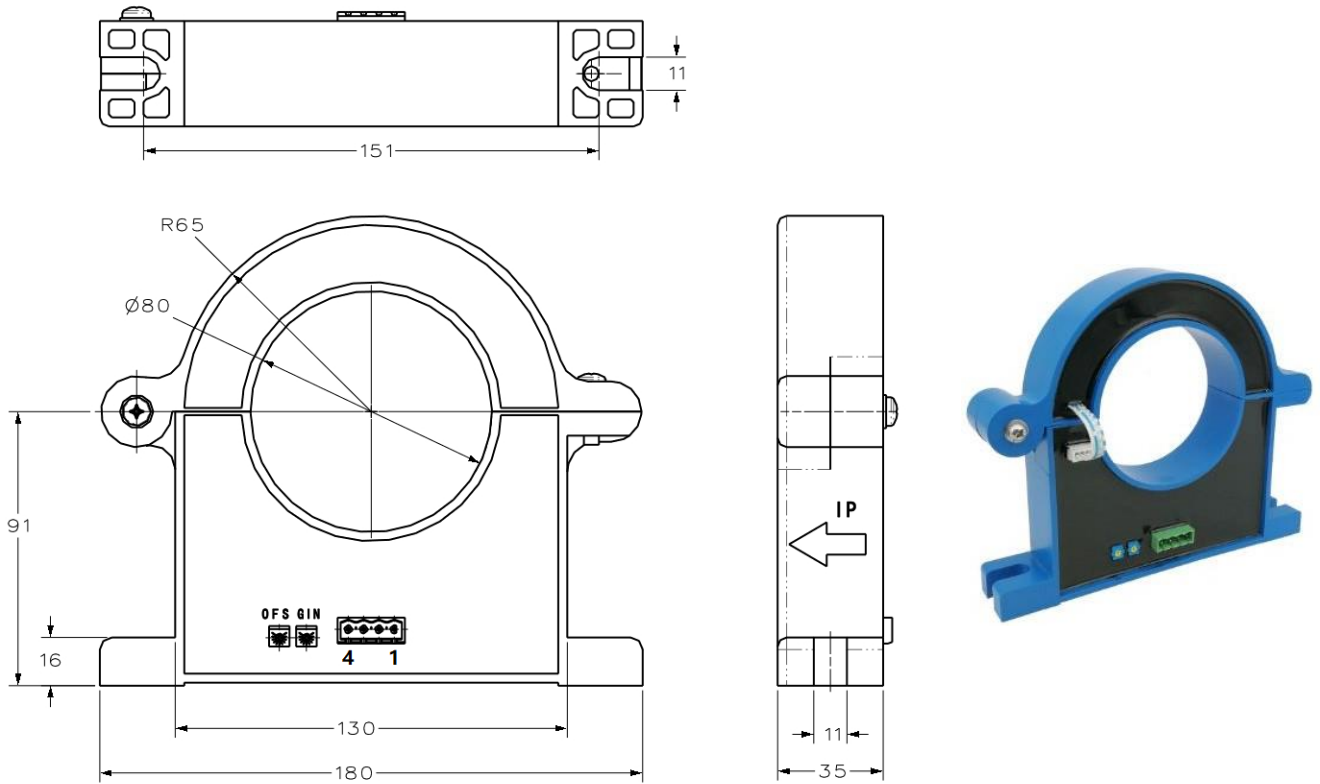

Fig. 2 Relation between the input current (AC) and output voltage (AC)



PIN Definition and Dimensions



OFS: Offset Adjustment

GIN: Gain Adjustment

Pin arrangement of connector:

1:	Vcc	2:	NC
3:	OUTPUT	4:	0V (GND)

Cable connection:

Red:	Vcc
Blue:	NC
Yellow:	OUTPUT
Black:	0V (GND)

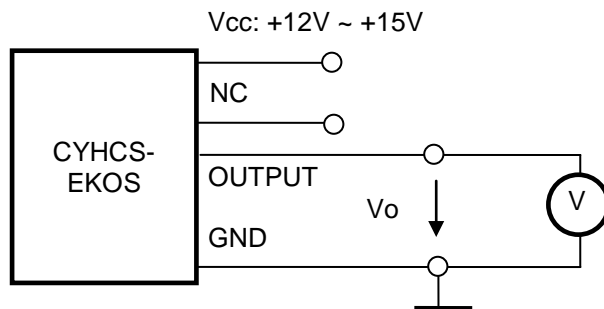

Notes:

1. Connect the terminals of power source, output respectively and correctly, never make wrong connection.
2. Two potentiometers can be adjusted, only if necessary, by turning slowly to the required accuracy with a small screwdriver.
3. The best accuracy can be achieved when the window is fully filled with current carrying conductor.
4. The in-phase output can be obtained when the current direction of current carrying conductor is the same as the direction of arrow marked on the transducer