

Closed Loop Hall AC/DC Current Sensor CYHCS-D8

This Hall Effect current sensor is based on closed loop compensating principle and can be used for measurement of DC and AC current, pulse currents etc. The output of the transducer reflects the real wave of the current in the carrying conductor.

Product Characteristics	Applications
<ul style="list-style-type: none"> • Excellent accuracy • Very good linearity • Small size and encapsulated • Less power consumption • Current overload capability 	<ul style="list-style-type: none"> • Photovoltaic equipment • General Purpose Inverters • AC/DC Variable Speed Drivers • Battery Supplied Applications • Uninterruptible Power Supplies • Switched Mode Power Supplies

ELECTRICAL DATA

Part number	CYHCS-D8-500A	CYHCS-D8-1000A
Nominal input current	500A	1000A
Measuring range	800A	0-1500A ~ 0-2000A
Turns ratio	1:5000	1:5000
Measuring resistance	with $V_c = \pm 15V$, @ $\pm 500A_{max}$, 0-60 Ω , @ $\pm 800A_{max}$, 0-12 Ω ,	with $V_c = \pm 15V$, @ $\pm 1000A_{max}$, 0-15 Ω , @ $\pm 1200A_{max}$, 0-4 Ω
	with $V_c = \pm 24V$, @ $\pm 500A_{max}$, 5-150 Ω , @ $\pm 800A_{max}$, 5-65 Ω	with $V_c = \pm 24V$, @ $\pm 1000A_{max}$, 5-55 Ω , @ $\pm 1500A_{max}$, 5-24 Ω @ $\pm 2000A_{max}$, 5-16 Ω
Nominal output current	100mA \pm 0.5%	200mA \pm 0.5%
Supply voltage	$\pm 15VDC \sim \pm 24VDC$	
Current consumption	$\leq 30mA$ + Output current at $V_c = \pm 15V$	
Galvanic isolation	50Hz, 1min, 6KV	
Secondary internal resistance	$T_a = 25^\circ C$, 40 Ω	

ACCURACY DYNAMIC PERFORMANCE

Zero offset current $T_a = 25^\circ C$	$< \pm 0.4mA$
Magnetic Offset current $I_P \rightarrow 0$	$< \pm 0.2mA$
Thermal drift of offset current	$I_P = 0$, $T_a = -25^\circ C \sim +85^\circ C$, $\pm 0.8mA$
Response time	$< 1\mu s$
Linearity	$\leq 0.1\% FS$
Accuracy at $+25^\circ C$	$\pm 0.5\% FS$
Bandwidth(-3dB)	DC...150kHz
di/dt	$> 100A/\mu s$

GENERAL DATA

Operating temperature	$-25^\circ C \sim +85^\circ C$
Storage temperature	$-40^\circ C \sim +100^\circ C$
Unit weight	510g

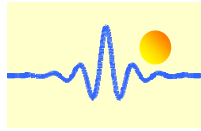

Dimensions (mm)

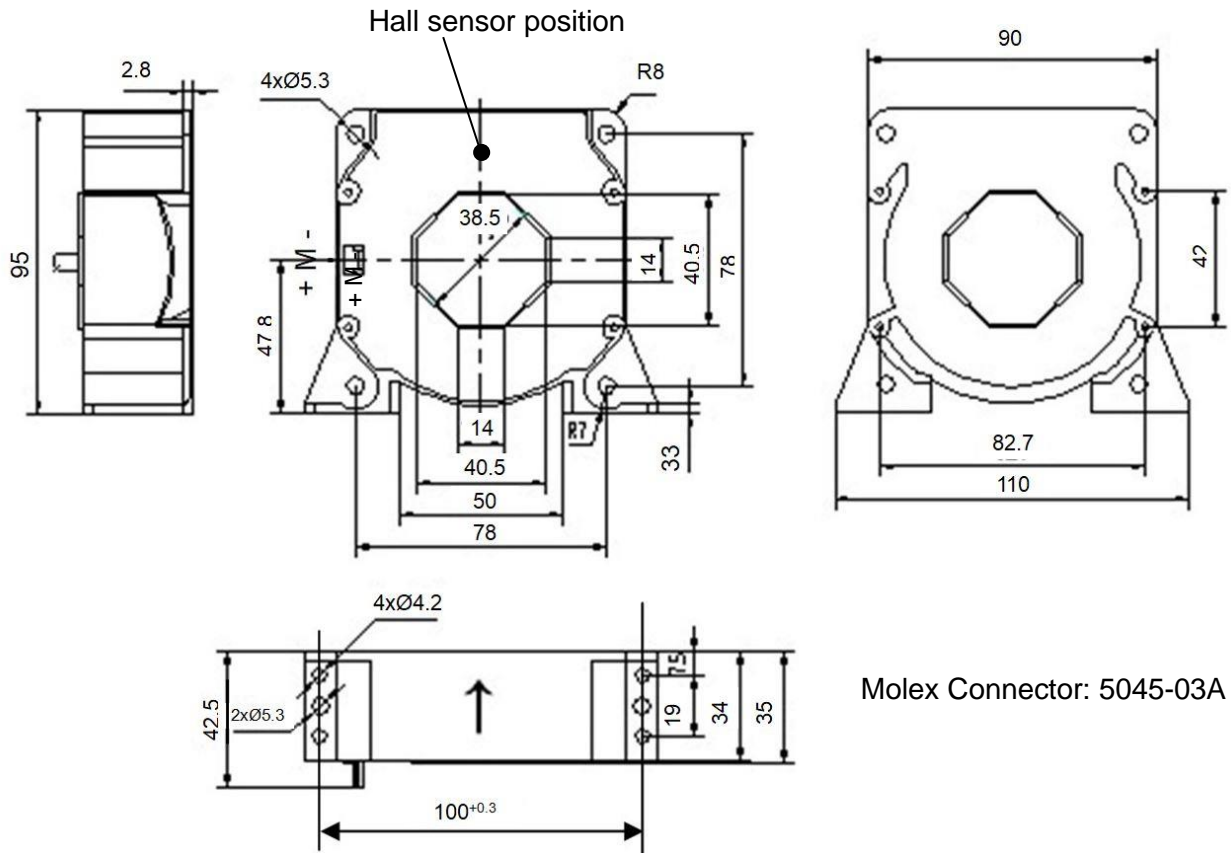

Molex Connector: 5045-03A

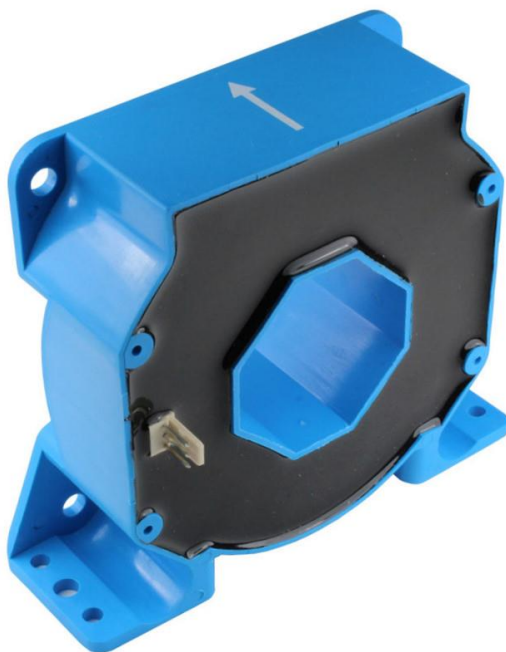

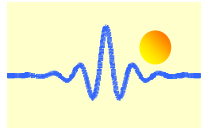

Sensor Connections

1) For Measurement of Bidirectional Current

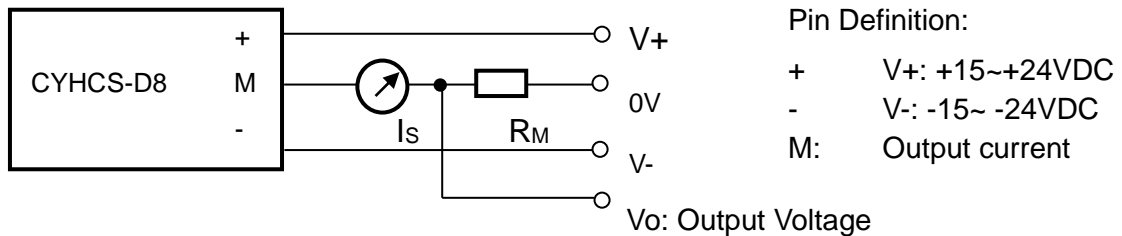

2) For Measurement of Unidirectional Current

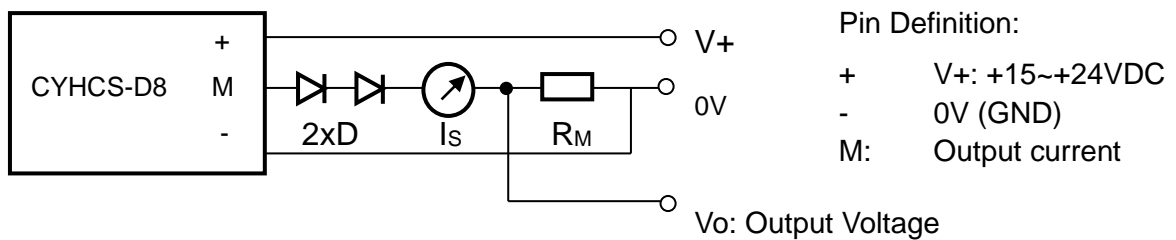

Two diodes for instance IN4007 must be connected at the output of the sensor in order to guarantee the sensor to work well.

Operating instructions

1. Connect the terminals of power source, output respectively and correctly, never make wrong connection for DC current.
2. Temperature of the primary conductor should not exceed 100 °C.
3. Dynamic performances (di/dt and the response time) are the best with a single bar completely filling the primary hole.
4. In order to achieve the best magnetic coupling, the primary windings have to be wound over the top edge of the device.