

## Hall Effect AC Current Sensor CYHCS-D6C

This Hall Effect current sensor is based on open loop principle and designed with a high galvanic isolation between primary conductor and secondary circuit. It can be used for measurement of AC current etc. The output of the transducer reflects the rectified average value of the current in the carrying conductor.

Product Characteristics	Applications
<ul style="list-style-type: none"> <li>• Excellent accuracy</li> <li>• Very good linearity</li> <li>• Less power consumption</li> <li>• Window structure</li> <li>• Electrically isolating the output of the transducer from the current carrying conductor</li> <li>• No insertion loss</li> <li>• Current overload capability</li> </ul>	<ul style="list-style-type: none"> <li>• <b>Photovoltaic equipment</b></li> <li>• Frequency conversion timing equipment</li> <li>• Various power supply</li> <li>• Uninterruptible power supplies (UPS)</li> <li>• Electric welding machines</li> <li>• Transformer substation</li> <li>• Numerical controlled machine tools</li> <li>• Electric powered locomotive</li> <li>• Microcomputer monitoring</li> <li>• Electric power network monitoring</li> </ul>

### Electrical Data

Primary Nominal rms Current $I_r$ (A)	Measuring Range (A)	DC Output Current $I_s$ (mA)	Part number
50	0 ~ ±50A	4-20 ±1.0%	CYHCS-D6C-50A-n
100	0 ~ ±100A		CYHCS-D6C-100A-n
200	0 ~ ±200A		CYHCS-D6C-200A-n
300	0 ~ ±300A		CYHCS-D6C-300A-n
400	0 ~ ±400A		CYHCS-D6C-400A-n
500	0 ~ ±500A		CYHCS-D6C-500A-n
600	0 ~ ±600A		CYHCS-D6C-600A-n
700	0 ~ ±700A		CYHCS-D6C-700A-n
800	0 ~ ±800A		CYHCS-D6C-800A-n
900	0 ~ ±900A		CYHCS-D6C-900A-n
1000	0 ~ ±1000A		CYHCS-D6C-1000A-n

(n=3,  $V_{cc}$ = +12VDC ±5%; n=4,  $V_{cc}$ =+15VDC ±5%; n=5,  $V_{cc}$ =+24VDC±5%)

Supply Voltage	$V_{cc}$ = +12V, +15V, +24V ± 5%,
Current Consumption	$I_c < 25\text{mA} + I_s$
Galvanic isolation, 50/60Hz, 1min:	5kV
Isolation resistance @ 500 VDC	> 500 MΩ
Accuracy at $I_r$ , $T_A=25^\circ\text{C}$ ,	$X < 1.0\%$ FS
Linearity from 0 to $I_r$ , $T_A=25^\circ\text{C}$ ,	$E_L < 1.0\%$ FS
Electric Offset Current, $T_A=25^\circ\text{C}$ ,	4mA
Thermal Drift of Offset Current,	<±0.005mA/°C
Response Time at 90% of $I_P$ ( $f=1\text{kHz}$ )	$t_r < 200\text{ms}$
Frequency bandwidth (- 3 dB):	20Hz - 20kHz
Load resistance:	80-450Ω
Mean Time Between Failures (MTBF):	50k - 100k hours

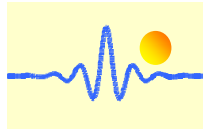

Ambient Operating Temperature,  
Ambient Storage Temperature,

$T_A = -25^{\circ}\text{C} \sim +85^{\circ}\text{C}$   
 $T_S = -40^{\circ}\text{C} \sim +100^{\circ}\text{C}$

## PIN Definition and Dimensions

### CYHCS-D6C-xxxx

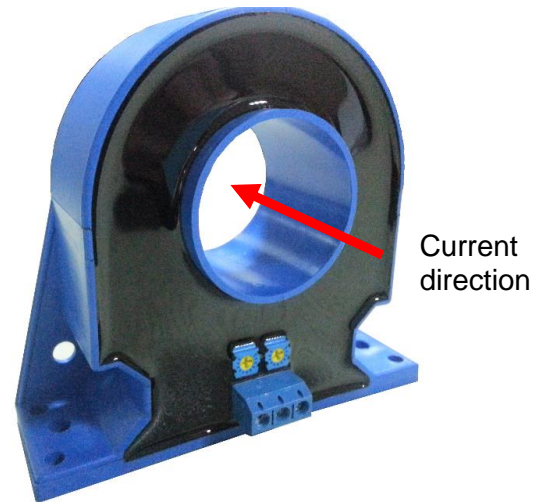
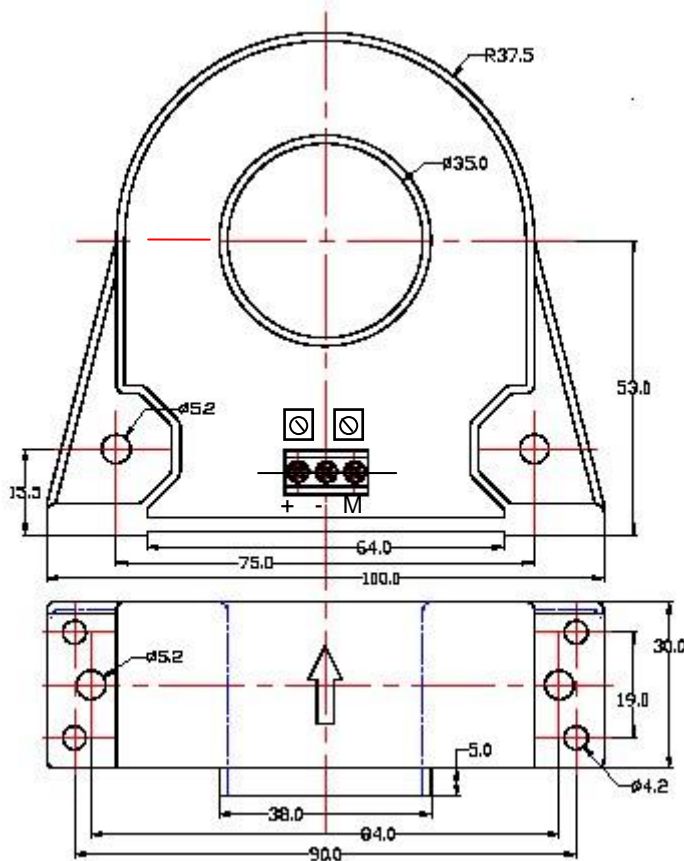

### Terminal Arrangement

- 1(+): Vcc
- 2(-): GND
- 3(M): Output

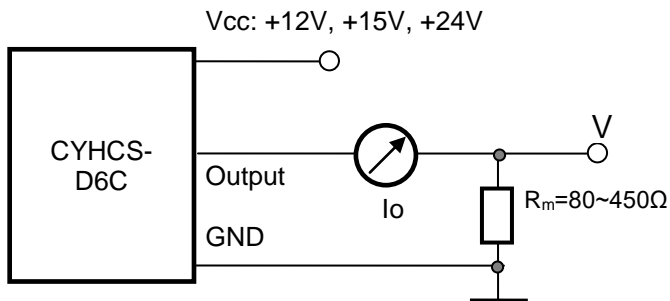

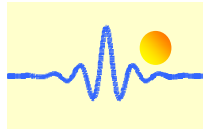

## CYHCS-D6C-xxxx

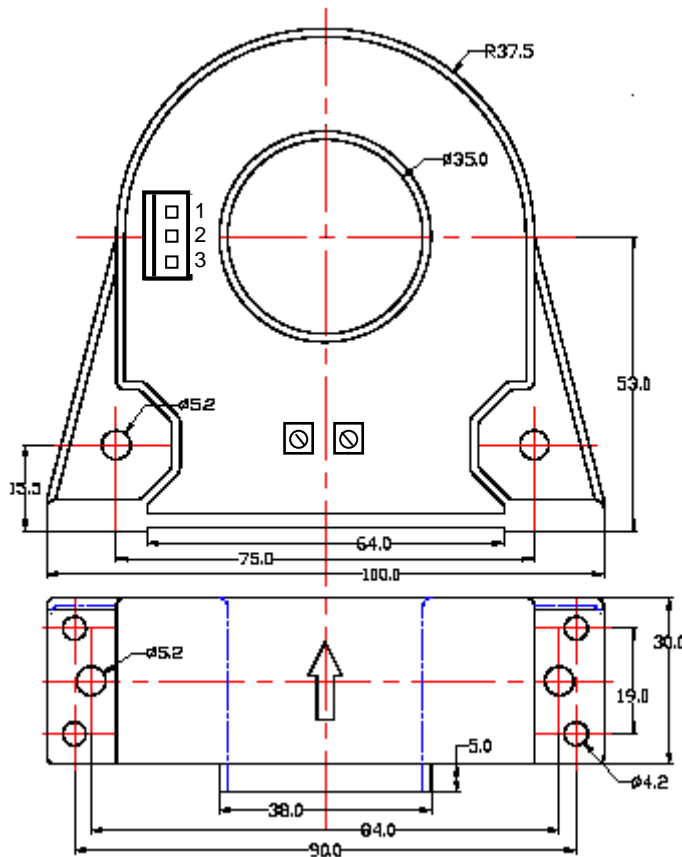

### Terminal Arrangement

1:	Vcc
2:	GND
3:	Output

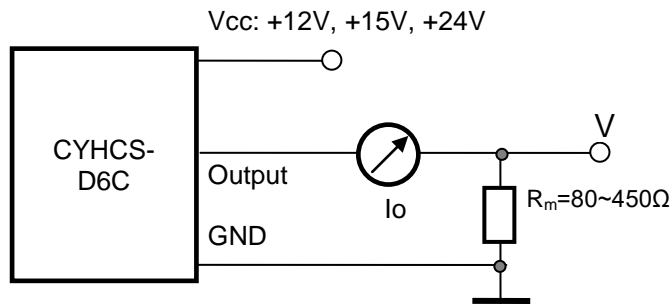

### Notes:

1. Connect the terminals of power source, output respectively and correctly, never make wrong connection.
2. Two potentiometers can be adjusted, only if necessary, by turning slowly to the required accuracy with a small screwdriver.
3. The best accuracy can be achieved when the window is fully filled with bus-bar (current carrying conductor).
4. The in-phase output can be obtained when the direction of current of current carrying conductor is the same as the direction of arrow marked on the transducer