

Closed Loop Hall AC/DC Current Sensor CYHCS-D5

This Hall Effect current sensor is based on closed loop compensating principle and designed with a high galvanic isolation between primary conductor and secondary circuit. It can be used for measurement of DC and AC current, pulse currents etc. The output of the transducer reflects the real wave of the current carrying conductor.

Product Characteristics	Applications
<ul style="list-style-type: none"> • Excellent accuracy • Very good linearity • Small size and encapsulated • Less power consumption • Current overload capability 	<ul style="list-style-type: none"> • Photovoltaic equipment • General Purpose Inverters • AC/DC Variable Speed Drivers • Battery Supplied Applications • Uninterruptible Power Supplies • Switched Mode Power Supplies

ELECTRICAL DATA

Part number	CYHCS-D5S/M100A	CYHCS-D5S/M200A	CYHCS-D5S/M300A	
Nominal current	100	200	300	A
Measuring range	300 ($\pm 18V$, 20 Ω)	600($\pm 18V$, 30 Ω)	900 ($\pm 18V$, 20 Ω)	A
Turns ratio	1:2000	1:2000	1:2000 or 1:3000	
Measuring resistance	with $\pm 12V$ DC			
	@ $\pm 100A_{max}$ 80(max)	@ $\pm 200A_{max}$ 80(max)	@ $\pm 300A_{max}$ 76(max)	Ω
	@ $\pm 200A_{max}$ 25 (max)	@ $\pm 500A_{max}$ 20(max)	@ $\pm 600A_{max}$ 22(max)	Ω
	with $\pm 15V$ DC			
	@ $\pm 100A_{max}$ 110(max)	@ $\pm 200A_{max}$ 120(max)	@ $\pm 300A_{max}$ 100(max)	Ω
	@ $\pm 200A_{max}$ 40(max)	@ $\pm 500A_{max}$ 30(max)	@ $\pm 600A_{max}$ 36(max)	Ω
Nominal analogue output current	50 $\pm 0.5\%$	100 $\pm 0.5\%$	150 $\pm 0.5\%$ or 100 $\pm 0.5\%$	mA
Secondary internal resistance	25	21	32	Ω
Supply voltage	$\pm 12 \sim \pm 18$			V
Current consumption	$\pm 15VDC$, 20 + output current			mA
Galvanic isolation	50HZ, 1min, 6			KV

ACCURACY DYNAMIC PERFORMANCE

Zero offset current	± 0.2	mA
Thermal drift of offset current	-25°C ~ +85°C, ± 0.5	mA
Response time	<1	μs
Linearity	≤ 0.1	%FS
Bandwidth(-3dB)	DC...100	kHz
di/dt following accuracy	>200	A/ μs

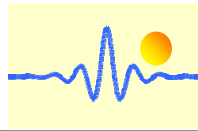

GENERAL DATA

Operating temperature	-25 ~ +85	°C
Storage temperature	-40 ~ +100	°C

Dimensions (mm)

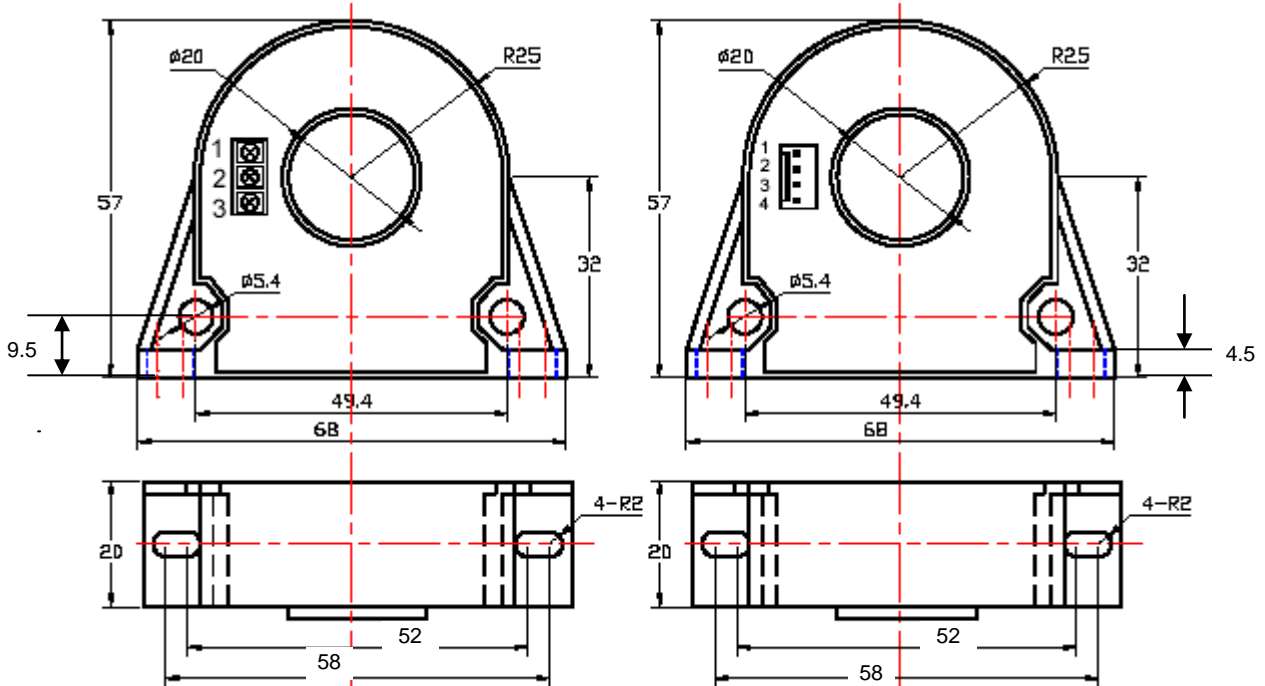

Screw Connector (P/N: CYHCS-D5Sxxxx)
DG300-5.0 Screw terminal block

Molex Connector (P/N: CYCS-D5Mxxxx)
Molex 22011042, 5045-04AG, 5051-04

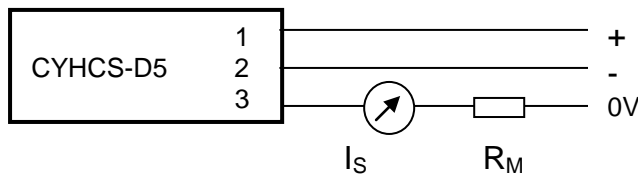

Pin & Terminal Arrangement

1(+): +15V
2(-): -15V
3(M): Output
4: NC

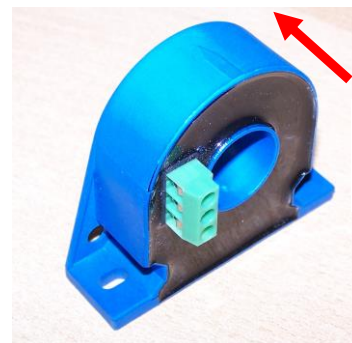

Current direction

Operating instructions

1. Connect the terminals of power source, output respectively and correctly, never make wrong connection for DC current.
2. Temperature of the primary conductor should not exceed 120 °C.
3. Dynamic performances (di/dt and the response time) are the best if the primary hole is completely filled with the bus bar.