

AC/DC Hall Effect Current Sensor CYHCS-C1T

This Hall Effect current sensor is based on open loop principle and designed with a solid core and a high galvanic isolation between primary conductor and secondary circuit. It can be used for measurement of DC and AC current, pulsed currents etc. The output of the transducer reflects the real wave of the current carrying conductor.

Product Characteristics	Applications
<ul style="list-style-type: none"> • Excellent accuracy • Very good linearity • Light in weight • Less power consumption • Window structure with split core • Electrically isolating the output of the transducer from the current carrying conductor • No insertion loss • Current overload capability 	<ul style="list-style-type: none"> • Frequency conversion timing equipment • Various power supply • Uninterruptible power supplies (UPS) • Electric welding machines • Numerical controlled machine tools • Electrolyzing and electroplating equipment • Electric powered locomotive • Microcomputer monitoring • Electric power network monitoring

Electrical Data

Primary Nominal Current I_r (A)	Primary Current Measuring Range I_p (A) at $V_{cc}=12V$	Output Voltage (analog) (V)	Part number
30	± 30	x=3: 2.5VDC \pm 2.5V x=8: 5VDC \pm 5V	CYHCS-C1T-30A-xnC
50	± 50		CYHCS-C1T-50A-xnC
100	± 100		CYHCS-C1T-100A-xnC
200	± 200		CYHCS-C1T-200A-xnC
300	± 300		CYHCS-C1T-300A-xnC
400	± 400		CYHCS-C1T-400A-xnC
500	± 500		CYHCS-C1T-500A-xnC

(n=2, $V_{cc}=+12VDC$; n=3, $V_{cc}=+15VDC$; n=4, $V_{cc}=+24VDC$,
Connector: Molex connector C=M; Phoenix Connector: C=P)

Current Consumption

RMS Voltage for 2.5kV AC isolation test, 50/60Hz, 1min,

Output Impedance:

Load Resistor:

Accuracy at I_r , $T_A=25^\circ C$ (without offset),

Linearity from 0 to I_r , $T_A=25^\circ C$,

Electric Offset Voltage, $T_A=25^\circ C$,

Magnetic Offset Voltage ($I_r \rightarrow 0$)

Thermal Drift of Offset Voltage,

Thermal Drift ($-10^\circ C$ to $50^\circ C$),

Response Time at 90% of I_p ($f=1k$ Hz)

Frequency Bandwidth (-3dB),

Mean Time Between Failures (MTBF):

$I_c < 25mA$

$V_{is} < 10mA$

$R_{out} < 150\Omega$

$R_L > 10k\Omega$

$X < 1.0\%$

$E_L < 1.0\%$ FS

$V_{oe}=2.5VDC \pm 1.0\%$ or $5VDC \pm 1.0\%$

$V_{om} < \pm 15mV$

$V_{ot} < \pm 1.0mV/^\circ C$

T.C. $< \pm 0.1\% /^\circ C$

$t_r < 7\mu s$

$f_b = 0-20$ kHz

50k - 100k hours

General Data

Ambient Operating Temperature,

Ambient Storage Temperature,

$T_A = -25^\circ C \sim +85^\circ C$

$T_S = -40^\circ C \sim +100^\circ C$

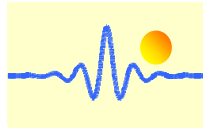

PIN Definition and Dimensions

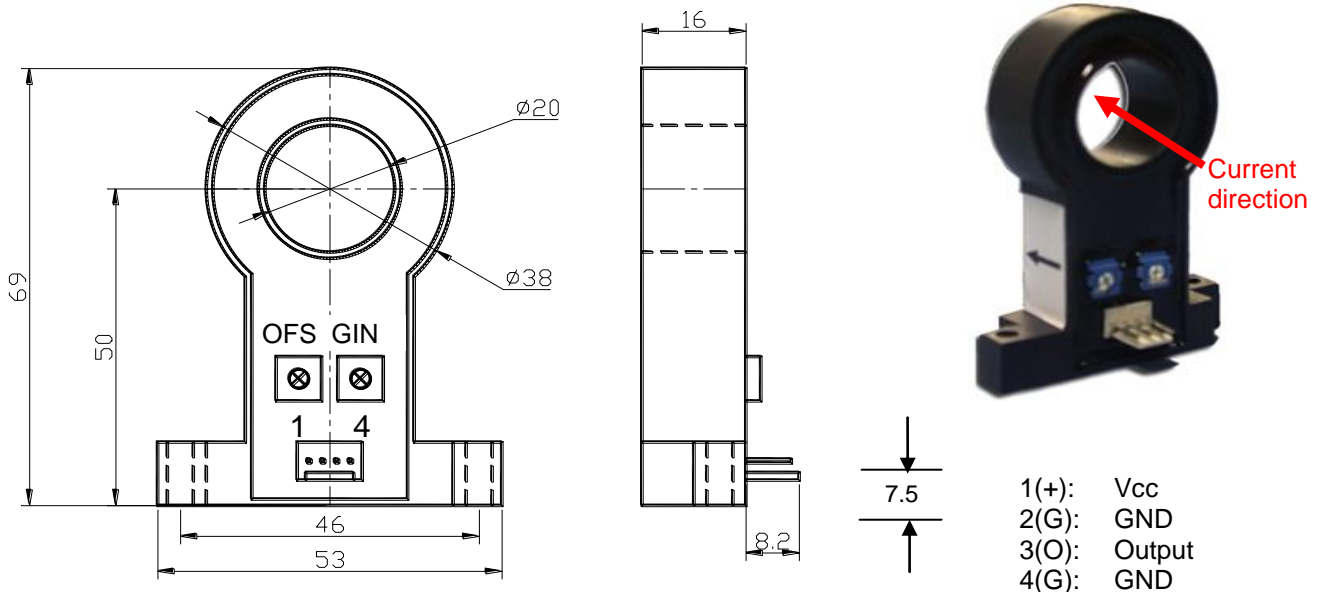

OFS: Offset Adjustment

GIN: Gain Adjustment

Connection

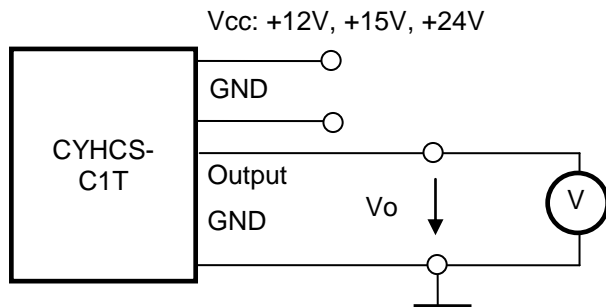

Notes:

1. Connect the terminals of power source, output respectively and correctly, never make wrong connection.
2. Two potentiometers can be adjusted, only if necessary, by turning slowly to the required accuracy with a small screwdriver.
3. The best accuracy can be achieved when the window is fully filled with bus-bar (current carrying conductor).
4. The in-phase output can be obtained when the direction of current of current carrying conductor is the same as the direction of arrow marked on the transducer