

AC Hall Effect Current Sensor CYHCS-BTC

This Hall Effect current sensor is based on open loop principle and designed with a high galvanic isolation between primary conductor and secondary circuit. It can be used for measurement of AC current, pulse currents etc. The output of the transducer reflects the rectified average value of the current in the carrying conductor.

Product Characteristics	Applications
<ul style="list-style-type: none"> • Excellent accuracy • Very good linearity • Light in weight • Less power consumption • Window structure • Electrically isolating the output of the transducer from the current carrying conductor • No insertion loss • Current overload capability 	<ul style="list-style-type: none"> • Photovoltaic equipment • Frequency conversion timing equipment • Various power supply • Uninterruptible power supplies (UPS) • Electric welding machines • Transformer substation • Numerical controlled machine tools • Electric powered locomotive • Microcomputer monitoring • Electric power network monitoring

Electrical Data

Primary Nominal Current I_r (A), rms	Measuring Range (A)	DC Output Current (mA)	Window Size (mm)	Part number
50	0 ~ ±50	4-20±1.0%	20.5x10.5	CYHCS-BTC-50A-n
100	0 ~ ± 100			CYHCS-BTC-100A-n
200	0 ~ ± 200			CYHCS-BTC-200A-n
300	0 ~ ± 300			CYHCS-BTC-300A-n
400	0 ~ ±400			CYHCS-BTC-400A-n
500	0 ~ ±500			CYHCS-BTC-500A-n
600	0 ~ ±600			CYHCS-BTC-600A-n

(n=3, $V_{cc} = +12VDC \pm 5\%$; n=4, $V_{cc} = +15VDC \pm 5\%$; n=5, $V_{cc} = +24VDC \pm 5\%$)

Supply Voltage	$V_{cc} = +12V, +15V, +24VDC \pm 5\%$
Output current:	4-20mADC
Current Consumption	$I_c < 25mA + \text{Output current}$
Galvanic isolation, 50/60Hz, 1min:	3kV rms
Isolation resistance @ 500 VDC	> 500 MΩ

Accuracy and Dynamic performance data

Accuracy at I_r , $T_A = 25^\circ C$,	$X < \pm 1.0\% \text{ FS}$
Linearity from 0 to I_r , $T_A = 25^\circ C$,	$E_L < \pm 0.5\% \text{ FS}$
Electric Offset current, $T_A = 25^\circ C$,	4mA DC
Thermal Drift of Offset Current,	$< \pm 0.005 \text{ mA}/^\circ C$
Response Time at 90% of I_P	$t_r < 200 \text{ ms}$
Load resistance:	80-450Ω
Frequency Bandwidth (-3dB),	$f_b = 20 \text{ Hz} - 20 \text{ kHz}$

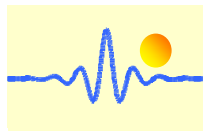

General Data

Ambient Operating Temperature,
Ambient Storage Temperature,

$T_A = -25^{\circ}\text{C} \sim +85^{\circ}\text{C}$
 $T_S = -55^{\circ}\text{C} \sim +100^{\circ}\text{C}$

PIN Definition and Dimensions

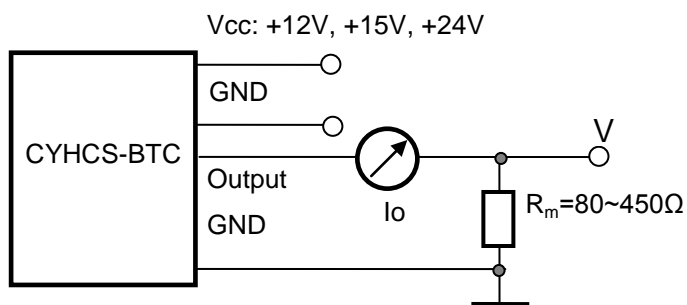
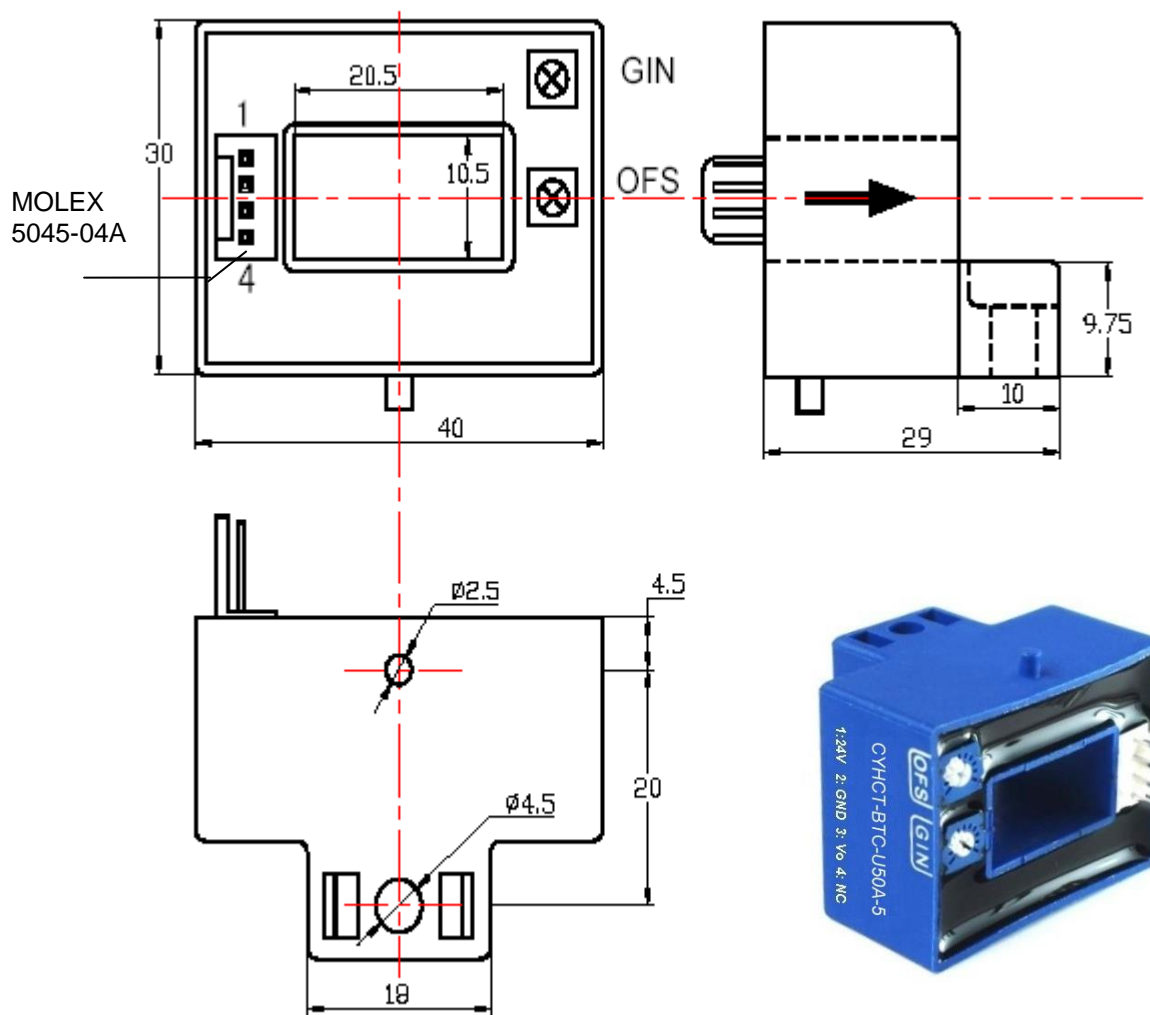

Pin Arrangement:

- 1: Vcc;
- 2: Ground;
- 3: Output;
- 4: NC

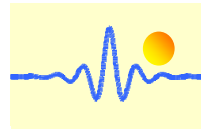

Notes:

1. Connect the terminals of power source, output respectively and correctly, never make wrong connection.
2. Two potentiometers can be adjusted, only if necessary, by turning slowly to the required accuracy with a small screwdriver.
3. The best accuracy can be achieved when the window is fully filled with bus-bar (current carrying conductor).
4. The in-phase output can be obtained when the direction of current of current carrying conductor is the same as the direction of arrow marked on the transducer